

# Design of a Manual Cattle Chute



**Joe Biggerstaff  
William Ryan Haar  
Matt Kilker  
Taylor Miller**

**BAE 4012  
May 2, 2006**



# Design of a Manual Cattle Chute

Joe M. Biggerstaff  
William R. Haar  
Matt S. Kilker  
Taylor F. Miller

## Biosystems & Agricultural Engineering Department Oklahoma State University

Submission Date: May 22, 2006

---

Joe M. Biggerstaff  
Biomechanical Option  
May 2006 Graduate  
Medford, Oklahoma

---

William R. Haar  
Biomechanical Option  
May 2006 Graduate  
Elkhart, Kansas

---

Matt S. Kilker  
Biomechanical Option  
December 2006 Graduate  
Brighton, Colorado

---

Taylor F. Miller  
Biomechanical Option  
December 2006 Graduate  
Carney, Oklahoma

---

Dr. Paul R. Weckler  
Senior Design Advisor

---

Dr. Ronald L. Elliott  
BAE Department Head



## **Abstract**

W-W Livestock Systems has been a competitive manufacturer of livestock handling equipment for many years. The company produces a manually operated cattle chute. Manually operated cattle chutes are advantageous over other chutes since they require no electrical power for their operation. There are many companies manufacturing a manual cattle chute which makes for a competitive market. W-W Livestock Systems has a well designed chute but current customer needs demand more. Custom Agricultural Solutions (CAS) has been assigned with the task of designing a new manually operated cattle chute. CAS did extensive research involving animal dimensions, animal health, and forces exerted on components of a chute during operation. CAS also interviewed several customers of W-W in order to design a chute that meets their needs. With this information, CAS designed a chute that is unlike any other on the market. Extensive field testing by CAS and area ranchers has proven that this prototype chute meets all of the design criteria set forth by W-W Livestock Systems.

## **Acknowledgements**

Chuck Vogt – W-W Livestock Engineer

Don Lake – Oklahoma State University Applications Engineer

Dr. Paul Weckler – Oklahoma State University Biosystems and Agricultural Engineering

Assistant Professor and Senior Design Advisor

Wayne Kiner – Oklahoma State University Biosystems and Agricultural Engineering

Laboratory Manager

Rolling R3 Ranch – Testing

Clay Burtrum Farms – Testing



## Table of Contents

<b>ABSTRACT</b> .....	<b>II</b>
<b>ACKNOWLEDGEMENTS</b> .....	<b>II</b>
<b>PROBLEM STATEMENT</b> .....	<b>1</b>
<b>STATEMENT OF WORK</b> .....	<b>1</b>
SQUEEZE MECHANISM ISSUES .....	2
HEADGATE ISSUES.....	3
TAIL GATE ISSUES.....	3
MISCELLANEOUS ISSUES.....	4
<b>PATENT AND LITERATURE SEARCH</b> .....	<b>7</b>
PATENTS .....	7
LITERATURE .....	8
<b>DESIGN SPECIFICATIONS</b> .....	<b>9</b>
<b>DESIGN CONCEPT</b> .....	<b>10</b>
HEADGATE .....	10
SQUEEZE MECHANISM.....	12
<i>Squeeze Mechanism Dimensions and Further Analysis</i> .....	16
TAILGATE .....	19
FLOOR .....	22
<b>DESIGN TESTING</b> .....	<b>23</b>
<b>DESIGN CHANGES</b> .....	<b>27</b>
<b>RECOMMENDATIONS</b> .....	<b>29</b>
<b>COST</b> .....	<b>30</b>
<b>WORKS CITED</b> .....	<b>32</b>
<b>APPENDIX A – GANTT CHART</b> .....	<b>33</b>





## List of Figures

<b>Figure 1. W-W Livestock System "BEEFMASTER" Current Chute Design...</b>	<b>1</b>
<b>Figure 2. Misalignment Due to Single Squeeze .....</b>	<b>2</b>
<b>Figure 3. Breast Plate Patent .....</b>	<b>7</b>
<b>Figure 4. Headgate Lever Detail.....</b>	<b>11</b>
<b>Figure 5. Neck Access Door.....</b>	<b>12</b>
<b>Figure 6. Symmetrical Squeeze.....</b>	<b>13</b>
<b>Figure 7. Top Squeeze Locking Mechanism.....</b>	<b>14</b>
<b>Figure 8. Bottom Squeeze Details .....</b>	<b>15</b>
<b>Figure 9. Squeeze Panels Fully Open and Fully Closed.....</b>	<b>17</b>
<b>Figure 10. Larger Animal Neck Access .....</b>	<b>18</b>
<b>Figure 11. Small Animal Neck Access.....</b>	<b>18</b>
<b>Figure 12. Finite Element Analysis .....</b>	<b>19</b>
<b>Figure 13. Guillotine/Slider Tail Gate.....</b>	<b>20</b>
<b>Figure 14. Scissor Tail Gate .....</b>	<b>21</b>
<b>Figure 15. Bottom View of Conceptual Floor.....</b>	<b>23</b>
<b>Figure 16. Top View of Conceptual Floor .....</b>	<b>23</b>
<b>Figure 17. First Large Bull Tested in Chute .....</b>	<b>24</b>
<b>Figure 18. Branding Interference Problem .....</b>	<b>25</b>
<b>Figure 19. Working Cattle at Jim Kinder Farms .....</b>	<b>26</b>
<b>Figure 20. Testing the Chute at Rolling R3 .....</b>	<b>27</b>
<b>Figure 21. Notch in Neck Access Panel.....</b>	<b>28</b>
<b>Figure 22. New Kick Panel Design .....</b>	<b>29</b>



## List of Tables

<b>Table 1. Suggested Chute Dimensions. Source: OSU Fact Sheet F-1738 .....</b>	<b>16</b>
<b>Table 2. Rumber® Specifications. Source: www.rumber.com.....</b>	<b>22</b>
<b>Table 3. Cost Breakdown .....</b>	<b>31</b>
<b>Table 4. Retail Cost Comparison.....</b>	<b>31</b>



## Problem Statement

W-W Livestock Systems has been a competitive manufacturer of livestock equipment since 1945. They have produced a quality manually operated cattle restraining chute for many years. However, their current design the “BEEFMASTER” needs updated in order to stay competitive in today’s market. Custom Agricultural Designs (CAS) accepted the task of improving the design of a manually operated cattle chute while considering the manufacturing and design constraints set forth by W-W Livestock Systems. The design must improve ease of operation and reduce stress on the animal.



**Figure 1. W-W Livestock System "BEEFMASTER" Current Chute Design**

## Statement of Work

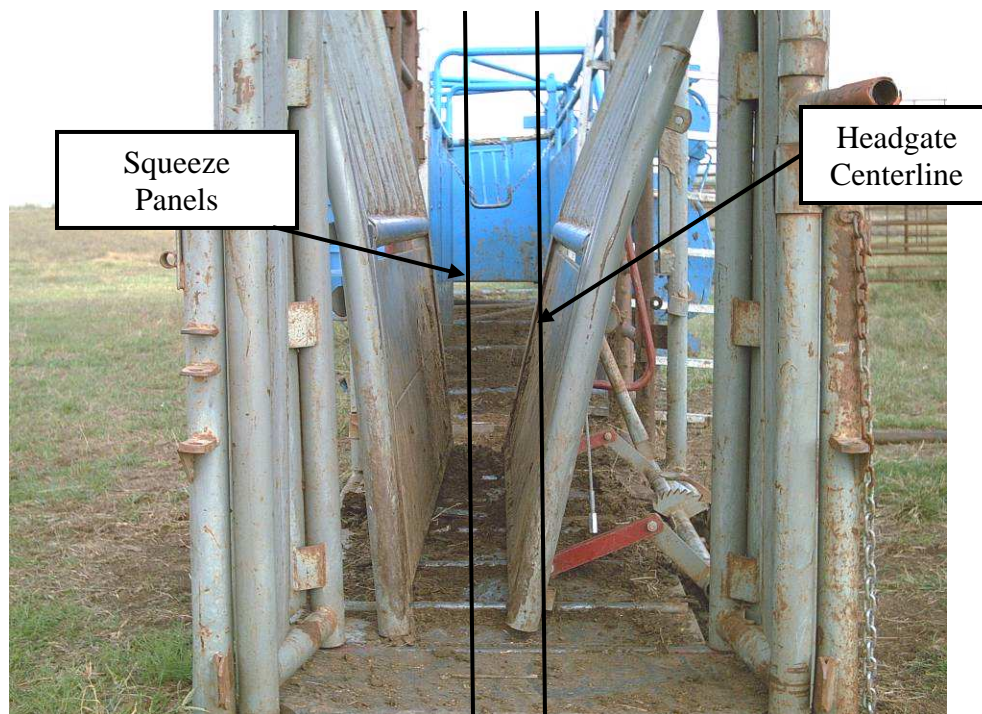
Representatives of W-W met with CAS in September to establish the design objectives for a new manual chute design. They have asked CAS to develop new ideas in compliance with their design constraints in order to help meet their objective of staying competitive in the



marketplace. CAS will begin the process by investigating problems encountered by owners of current W-W chutes. CAS will then generate design concepts, model these concepts, and build a prototype unit for testing and further evaluation by W-W personnel.

## Squeeze Mechanism Issues

The squeeze mechanism is a primary concern of the current design. W-W expressed concern over their current chutes inability to squeeze from both sides. Currently their chute squeezes from only one side which causes the centerline of the squeeze to be out of line with the centerline of the head gate. This causes misalignment of the spine of the animal, being ultimately detrimental to the health of the animal as shown in Figure 2.



**Figure 2. Misalignment Due to Single Squeeze**

The misalignment of the squeeze panels is not the only aspect of the chute that causes health problems for the animal. The squeeze panels produce a significant amount of noise during operation. The mechanism that attaches the squeeze panels to the floor is the primary cause of

the excessive noise. Loud noise increases the stress on the animal during treatment which increases the likelihood of sickness. Noise from the chute must be reduced or preferably eliminated in the prototype unit.

The final concern addressed is the operation of the chute needs to be easy for any operator from one position. It would be optimal for the chute to be able to be controlled from the left or right side of the chute. The squeeze must also retain the emergency exit or side exit which can be easily opened by the operator. Increasing the angle at which the emergency exit can open should be considered.

## Headgate Issues

W-W Livestock Systems asked CAS to improve the latching mechanism of the headgate, as the current design requires constant adjustment to work correctly. The current latch is designed to enable the operator to swing the headgate back to the catch position without pulling the latch lever. However, the back latch must be aligned in a very precise location to catch the headgate properly. The spring that returns the back latch must be adjusted properly in order for the latch to return to its correct position. W-W also requested that the operating controls be placed in such a manner that the chute may be operated from the left or right side. W-W would like for CAS to redesign the latching mechanism in order to increase the reliability of the latch and the ease of manufacturing.

## Tail Gate Issues

The tailgate is a great area of concern for W-W. Weaker operators complain that they cannot actuate the tailgate. W-W needs a tailgate that can be actuated by anyone from small children to grown men. However, the tailgate must be structurally sound due to the loads



imposed on it during operation. When developing the structure of the concept tailgates, CAS should explore ways to reduce noise that can be attributed to metal on metal contact.

## Miscellaneous Issues

W-W is addressing the issue of noisy operation in cattle equipment. In order to reduce the noise levels while working cattle, W-W wants to incorporate a Rumber floor. They suggested designing a new floor support that will allow the steel C-channel to be replaced by common sized Rumber. The cross members must be close enough to support the Rumber and restrict the Rumber from deflection. Noise will be reduced by reducing the number of metal on metal contacts. The use of polyurethane bushings along with rubber on all contacting surfaces will be implemented.

This particular model of chute uses a special yoke trailer for transport. The design of the trailer simplifies transportation of the chute from one location to the next. Changes to the yoke trailer are needed in order to accommodate the concept unit. The trailer must balance the chute properly. Height of the chute on the trailer is also a consideration so that clearance does not become an issue.

## Testing and Observations

In order to find solutions for the problems with the current W-W chute, CAS interviewed ranchers from all over the state of Oklahoma. These ranchers expressed many of the same concerns as W-W. One aspect that CAS quickly learned was that every rancher preferred something different. Ranchers with large cattle breeds such as Simmental and Chianina breeds complain about the small size of the chute. Ranchers with smaller breeds indicate that the size is fine. Some ranchers like a guillotine gate, some a slider, some a scissor-type and so on.



CAS went to Rolling-R3 Ranch to work cattle and witness the problems of the, “BEEFMASTER” firsthand. CAS met with Jason Shepard, the cow herd manager for Rolling-R3 Ranch. At the meeting, the team began by discussing the changes which W-W had already suggested. After all the aspects already covered between CAS and W-W were discussed in detail, Mr. Shepard began to explain, and show the team members the problems with the chute which he had encountered in his six years of experience with the “BEEFMASTER” manual chute.

Eleven areas of concern were pointed out by Mr. Shepard:

- The rubber floor in the headgate- The two rubber planks in the head gate raise up out of placement from time to time due to material build up and cattle impact. Once the pieces are out of place, the head gate catches on the floor and restricts movement resulting in failure to open and close the head gate.
- The latching mechanism on the headgate latch- The mechanism uses a round bar with an ear on the end to restrict the latch from moving upward; hence, locking the headgate shut. The round bar must move laterally through two sleeves. The bar catches in the sleeves and does not move freely, causing difficulties in unlocking the headgate latch.
- Tailgate- The guillotine type tailgate is in the way when using the palpation gate and performing artificial insemination on cattle. A slider type tailgate would be more desirable for the applications used by R3 Ranch.
- Latches on the kick panels- The nuts which attach the pull cables to the latches back off and the cables come unscrewed.





- Emergency Exit Latch- The latch on the exit is not reliable. Nearly 25% of the time, the gate does not latch; therefore, the operator must go around the chute and manually push the gate shut.
- Emergency Exit Gate- The gate does not swing open on its own. The gate must be pulled or pushed open manually, which is very inconvenient for the operator.
- Bottom width Adjustment- The movement of the squeeze panel becomes very restricted after time due to material build up and steel rust.
- Squeeze Pull Handle- The handle is very hazardous to tall operators due to the low placement. The handle height should be adjustable to accommodate all sizes of operators.
- Releasing the Squeeze- In the situation of downed cattle, the release of the squeeze is very difficult due to the low resolution of the gearing on the latch. In some cases, releasing requires more than one person; which is very undesirable.
- Transporting the Chute- The current design on the yoke trailer requires a bar to be placed all the way across the back of the chute. When placing the chute in work areas, this is very inconvenient. The chute must be dropped forward of the desired working location and moved back into place.

After Mr. Shepard had completed his discussion, the team worked a few 1500 lb Angus cattle and encountered many of the problems described. This experience gave CAS a much better understanding of the problems. With this knowledge, CAS can design a chute more efficiently.

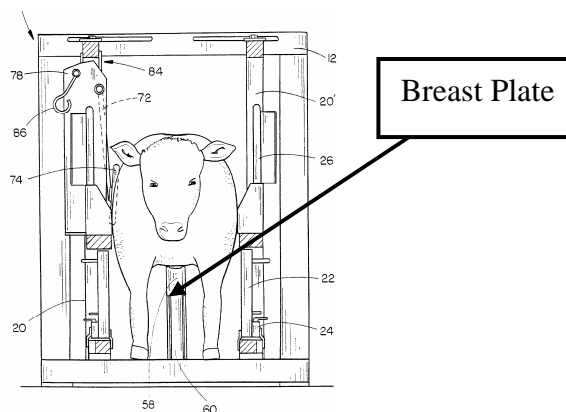


## Patent and Literature Search

CAS has done extensive research involving the development of the new W-W concept chute. We determined that the research must involve patent and article research as well as the communication with operators of the current W-W chute. The summary of the information gathered will help guide the design team in the development of the concept unit.

### Patents

Many patents involve the design of cattle chutes; however, most are out of date and will not affect the prototype design. The more recent patents concern all of the working entities of hydraulic chutes. United States Patent 4,027,629 involves a design that appears useful. This patent is from June 7, 1977 and is expired. One patent of concern to CAS is United States Patent 6,609,480 B2, referring to the use of an abdomen support to reduce the incident of bovine going down in the chute. The abdomen support, as shown in Figure 3, is referred to as a breast plate. A breast plate, used to keep the bovine elevated while in the chute, was found to be a very interesting idea. The use of the breast plate will not allow cattle to drop all the way down in the chute; thus solving the problem of restricted release of the squeeze mechanism. This is the only attachment that we are considering adding to the chute that poses an infringement problem.



**Figure 3. Breast Plate Patent**

## Literature

CAS found little information in the literature review or testing of cattle chutes. However, Maghirang (2001) wrote an interesting paper on the testing of a head gate. The head gate is a very critical aspect in the design of a cattle chute. By visiting with local ranchers and through CAS's experiences at Rolling-R3, the team determined that the headgate is crucial to the design of the chute. Cattle can only see out of the headgate area when entering the chute. Therefore, cattle view the headgate as their only exit and will lunge or try to run out of the head gate. This leads to the concern that the structure supporting the head gate is subject to large forces.

The purpose of the experiment conducted by Maghirang (2001) was to develop an energy-absorbing headgate. The article indicates that the headgate inflicts bruises on 2 to 8% of cattle that are restrained in a chute. In some cases, the headgate can kill cattle with excessive pressure on the carotid arteries. Many newer head gate designs use a metal gate that moves transverse to restrain the head of the animal. The headgate is made entirely of mild steel and all of the contacting surfaces are steel on steel. This results in a sudden stop when the animal hits the headgate. This rapid change in momentum is detrimental to the animal's health.

Maghirang (2001) began by using load cells to measure the forces induced on the headgate with an energy-absorbing device. Heifers ranging from 792 to 1012 lb. were used in the experiment. The measured impact forces ranged from 360 to 2900 lb. The energy absorbing headgate absorbed 19 to 46% of the energy; resulting in less strain on the animal. After reading this article, the design team will pursue a way to have an energy absorbing device on the headgate. This will cause less stress on the animal and the stresses in the material will not be as large.



Dr. Temple Grandin, assistant professor at Colorado State University, published articles on animal welfare and restraint. Grandin (2000) discusses many significant points to consider when restraining animals. She indicates that cattle become excited and agitated in a squeeze chute and will have lower weight gains and are more likely to have dark cutting meat.

Dr. Grandin gives suggestions on chute design:

- Encourage slow steady motion to calm an animal, as opposed to sudden jerky motion.
- Engineer equipment to minimize noise
- Use solid barriers on sides so that the only exit the animal sees is the headgate
- Use optimum pressure. Provide enough to make the animal feel restrained but do not apply so much pressure that the animal is inflicted with pain.
- Provide non-slip floors

## **Design Specifications**

W-W told CAS that they would entertain any design concepts. However, if the following criteria are not met in the concept design, the design will not be implemented. W-W indicated that these criteria are very strict and cannot deviate.

- Break down the chute into components. The components must be small enough to fit into their powder coating booth which has an opening of approximately (36" X 120").
- Saddle pipe to meet their current practices.
- Squeeze from both sides.
- Maintain emergency or side exit.
- Reduce noise.



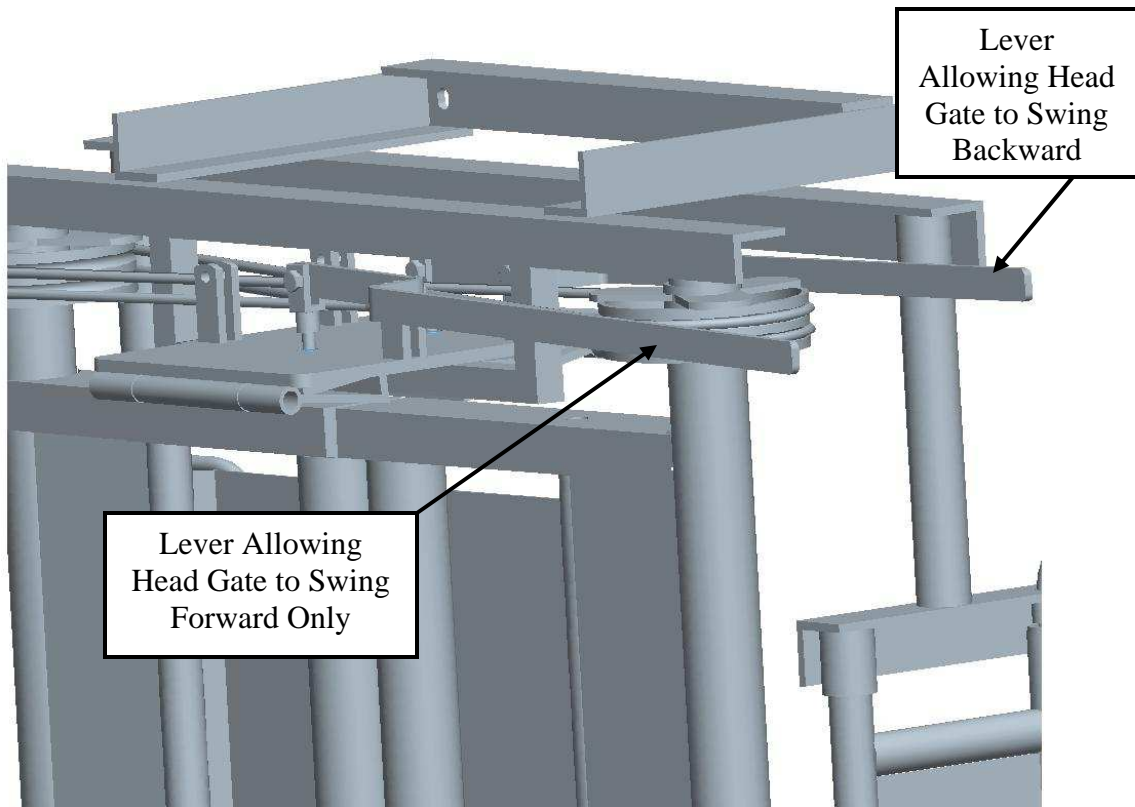
## Design Concept

CAS has designed a livestock chute that is more versatile than any other chute on the market. With the proposed design, the operator will be able to run an 1800 lb. bull through the chute and then be able to run a 200 lb. calf directly after that bull and not have to stop to make adjustments. With a design this versatile and safe, the operator will save a significant amount of time and labor. The controls for this chute can be installed on either the left or right side of the chute depending on the operator's preference. All controls are accessible while the operator stands in one place, and are placed in a safe position.

## Headgate

To obtain a reliable headgate latching mechanism, CAS has designed a two lever latching system. The design has a front and rear latch which restricts the headgate panels from forward or backward motion. The latches are spring actuated to insure that each latch closes without operator input. Each latch can act independently with a selected lever. Figure 4 shows the positions of each latch while the head gate is restricted to forward motion only. This design allows the latch to have a significant amount of downward motion to secure the headgate which solves the problem with the current W-W headgate latch design. As illustrated in Figure 4, this design has a great deal of versatility allowing the operator to work quickly and efficiently.



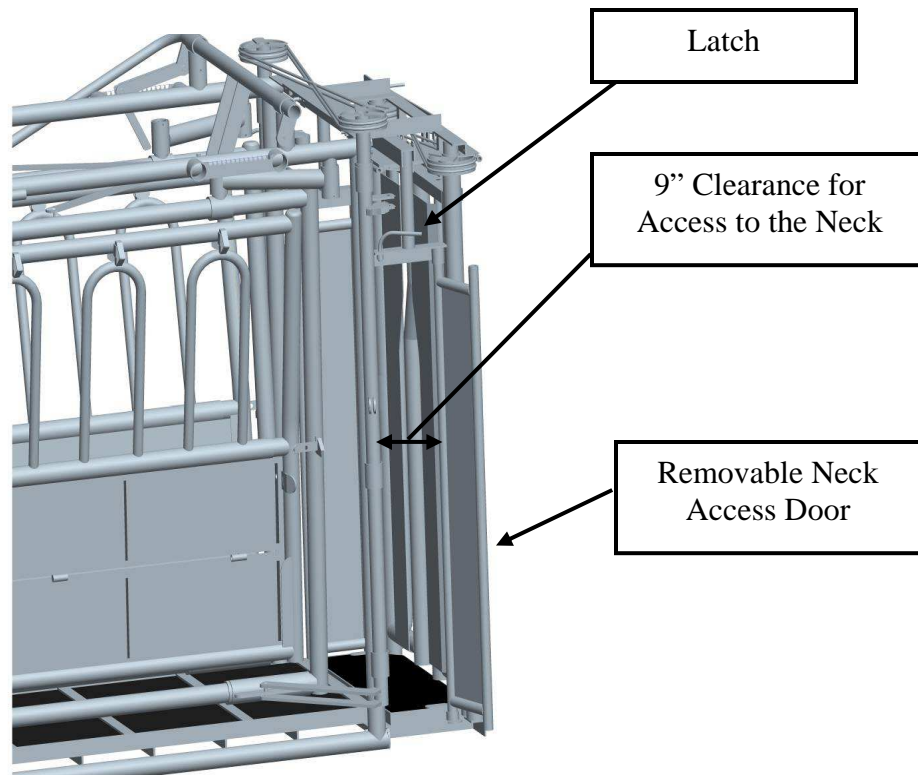


**Figure 4. Headgate Lever Detail**

CAS utilized experimental data from Maghirang (2001) for the stress analysis on the vital components of the headgate. CAS used the data to size the pins and structure that support the members absorbing the force of an animal hitting the head gate.

When consulting with many chute operators, a primary area of concern on the head gate was access to the neck of the bovine. The neck area is a location where large amounts of medications are administered. CAS has developed a removable neck access door that swings open or can be removed in order to address this issue. The neck access door of the head gates are easily opened by pulling on a latch and swinging the gate forward toward the front of the head gate as illustrated in Figure 5. The neck access door can then be removed if desired by pulling the gate out of the bottom pivot and then the top pivot. Nine inches of room allows

operators the needed area needed for application of various medications. When medications have been administered the door is easily closed and latched.

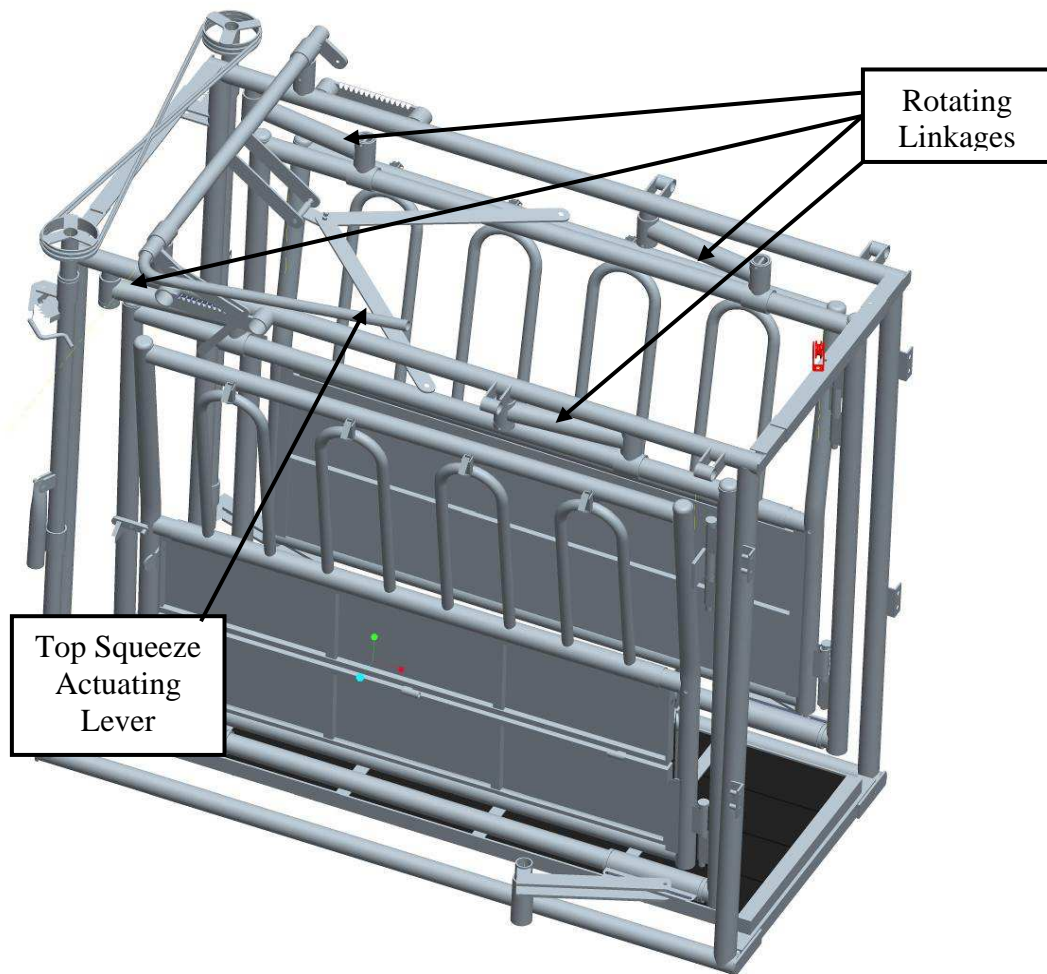


**Figure 5. Neck Access Door**

### Squeeze Mechanism

In order to meet the design specifications of squeezing from both sides, CAS has employed a design which moves inward and forward. By mounting each of the squeeze panels to a pair of linkages that rotate the squeeze panels toward one another equally, both sides squeeze together. This provides a symmetrical squeezing action. Since the squeeze panels are constrained to a circular motion, the squeeze moves forward as well when the squeeze is actuated as shown in Figure 6. The squeezing action of this design is similar to the design of United States Patent 4,027,629.



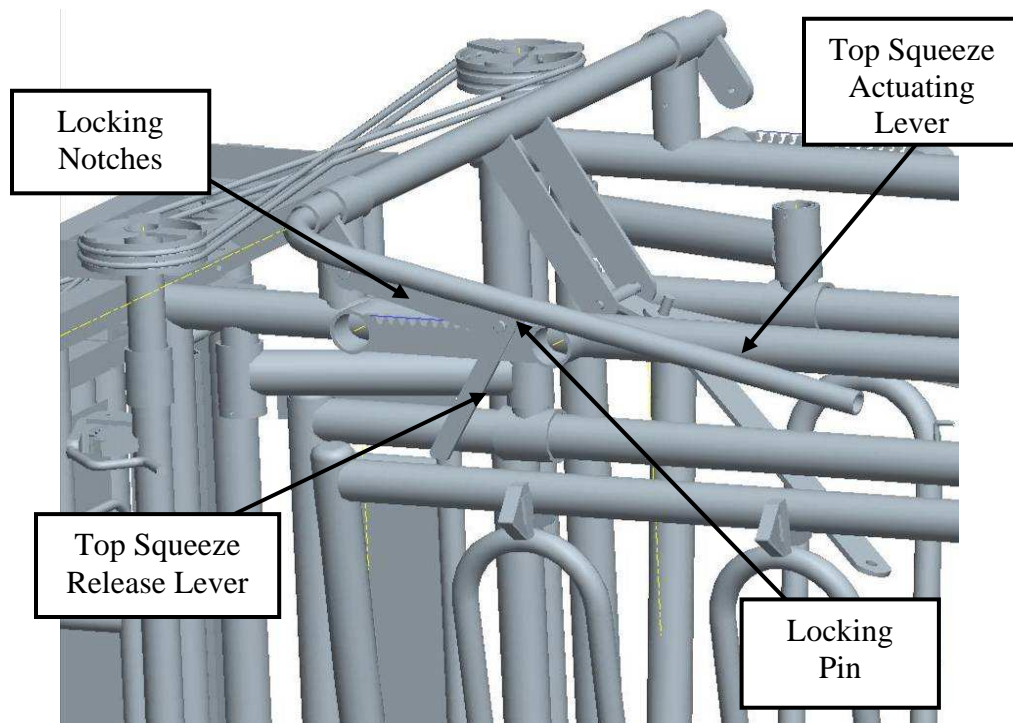


**Figure 6. Symmetrical Squeeze**

The squeeze is divided into a top squeeze portion and a bottom squeeze portion. Each respective squeeze is actuated by simply pulling a lever. If the operator so desires, he or she can pull the lever that actuates the top portion of the squeeze and the bottom follows accordingly. In this mode, the squeeze panels move together nearly parallel and the operator can ignore the bottom squeeze portion.

The lever for the top squeeze is 34 inches long which will give a weaker operator enough mechanical advantage to squeeze the animal tighter than the current design. The lever rotates approximately 75 degrees from all the way closed to fully open. The squeeze is locked in place by a piece of strap that is linked to the rotating squeeze axle. This piece of strap locks against a

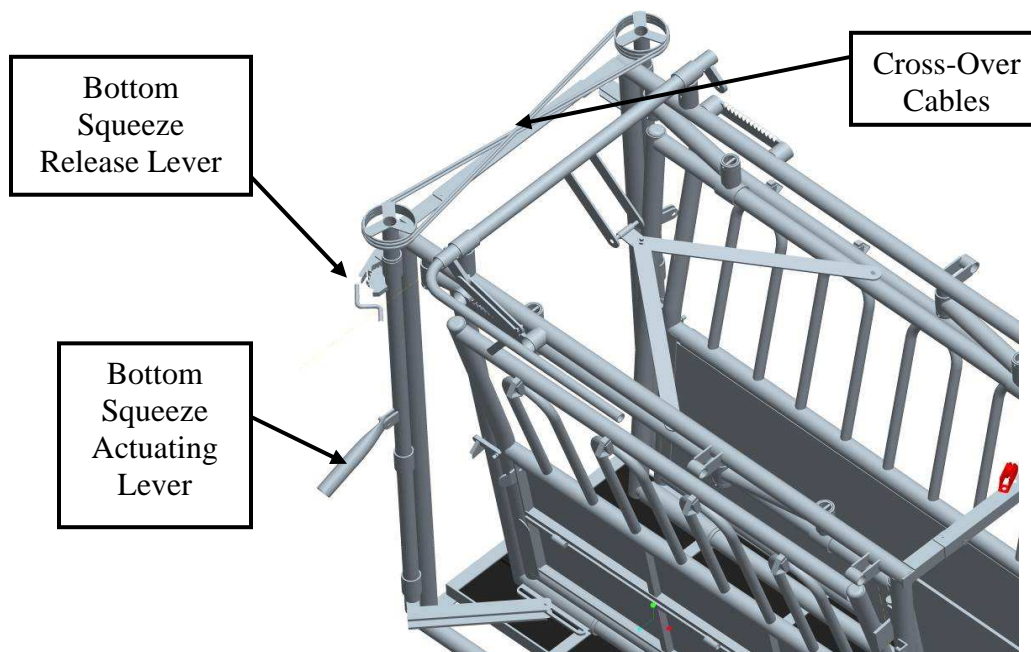
set of notches as shown in Figure 7. With this many degrees of rotation and the fine pitch of the locking notches, the operator has a fine tuned adjustment on the squeeze of the animal. When the operator wants to release the animal, they simply pull the squeeze lever downward; lift the lever on the locking strap, and the squeeze releases.



**Figure 7. Top Squeeze Locking Mechanism**

With this type of squeezing motion, the narrower the squeeze, the farther forward the squeeze panels are positioned toward the head of the animal. This feature solves the problem of the squeeze panels only restraining a small portion of the rear of a small calf while keeping the spine aligned with the central axis of the chute. When a smaller calf is in the chute, the squeeze panels will restrain more of the calf's body as compared to the current W-W design. When a larger animal is in the chute, the squeeze panels will be further back which improves neck access where many vaccinations are administered.

The ability to conveniently and independently adjust the bottom portion of the squeeze is crucial. The CAS bottom squeeze design is a first for manually operated chutes. With most manual chutes on the market, the bottom squeeze cannot be adjusted once an animal is in the chute. The bottom squeeze on this chute is operated independently from the main top squeeze by simply actuating a lever as shown in Figure 8. This lever is hinged on a bolt and will conveniently fold out of the way while not in use.



**Figure 8. Bottom Squeeze Details**

When the top squeeze is actuated, the bottom squeeze is linked so that the squeeze panels are parallel. Once the operator has the animal squeezed, they can use the bottom squeeze lever to obtain more squeeze on the bottom if they so desire. Operators like to make the bottom narrower than the top because this provides a lifting action on the animal and will prevent the animal from “choking down.” The operator also has the option to initially set the bottom squeeze and leave it when restraining the animal. A lever and a ratchet gear shown in Figure 8 lock the bottom

squeeze. The release latch is conveniently located near the front of the chute where the rest of the actuating functions are operated. A set of cross-over cables, similar to the current head gate design, are used to actuate the bottom squeeze on the other side of the chute.

### Squeeze Mechanism Dimensions and Further Analysis

CAS consulted beef producers, OSU fact sheets, and ASAE standards to determine the operating dimension of the squeeze mechanism. Dimensions of cattle vary from breed to breed. This variation complicates the decision for the squeeze dimensions that will have the optimum effect on restraining the animal. Information from the three sources will determine the dimensions of the squeeze panels.

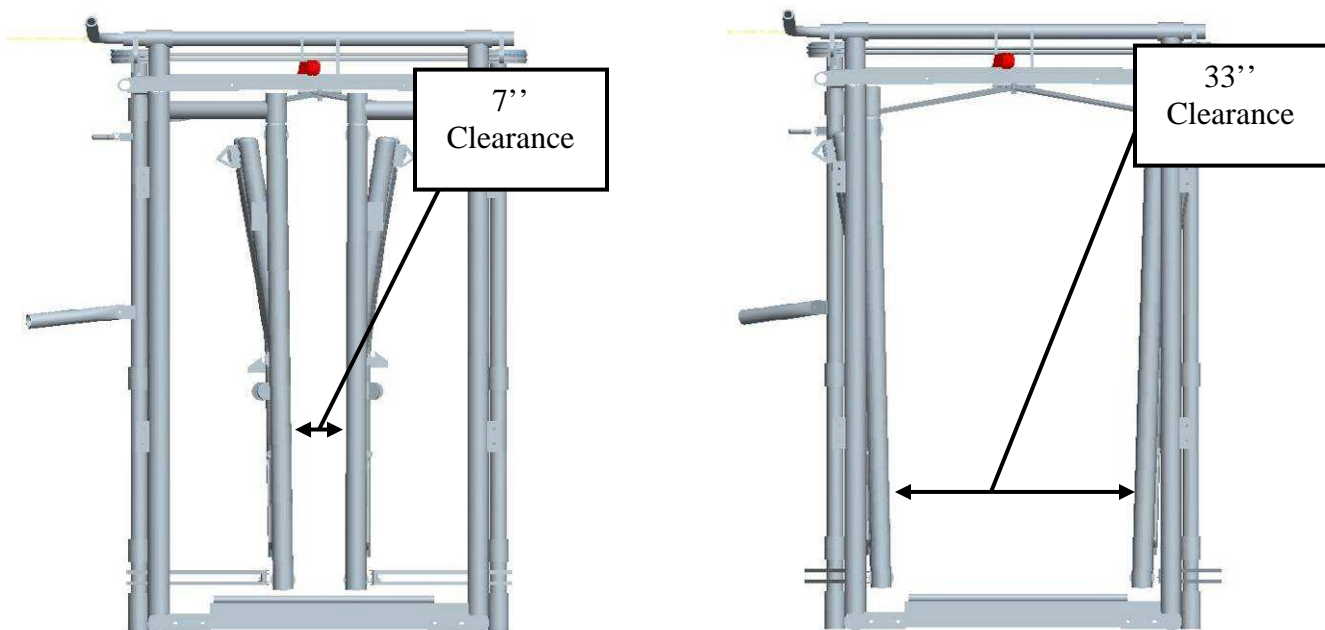
All of the beef producers consulted agreed that the current W-W design squeeze panel dimensions are fine for smaller animals or smaller built breeds such as Angus, etc. but the chute is not large enough for large cows or larger breeds such as Simmental or Chianina. The squeeze panels need to open wider at the bottom and the squeeze panels need to be longer. Table 1 from OSU Fact sheet F-1738 outlines suggested dimensions for different sizes of cattle.

**Table 1. Suggested Chute Dimensions. Source: OSU Fact Sheet F-1738**

	<b>Animal Size</b>		
	<b>to 600 lbs.</b>	<b>600-1200 lbs.</b>	<b>Over 1200 lbs. and cow calf operation</b>
<b>Working Chute with Vertical Sides</b> Width	18"	20-24"	26-30"
<b>Working Chute with Sloping Sides</b> Width at bottom, inside clear	13"	15"	16"
Width at top, inside clear	20"	24"	28"

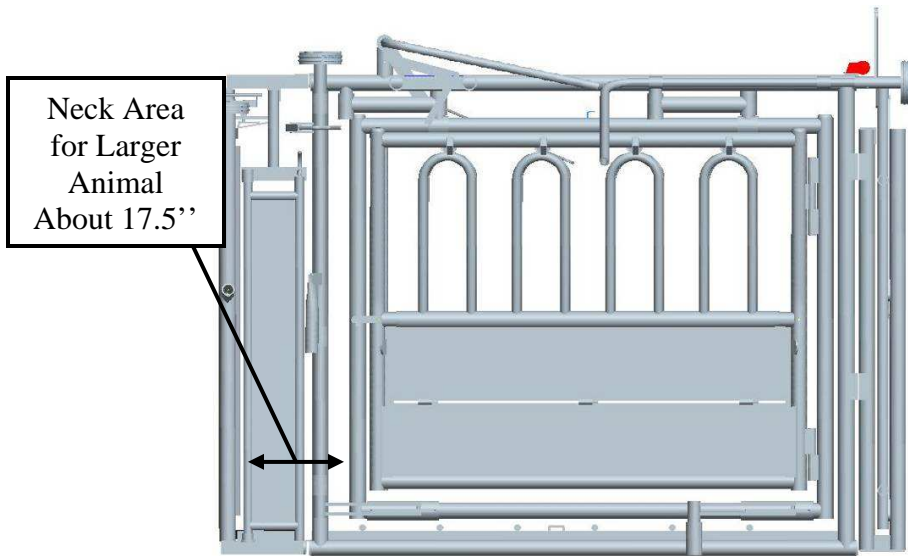


CAS analyzed ASAE Standard D321.2 JAN01 for chute dimensions as well. This standard gives dimensions of various animals. The thickest part of the animal occurs at the bulge of the belly. For a 1300 lb. steer this dimension is roughly 33 inches. The smallest thickness occurs at the center of the foreleg at the knee. This dimension is approximately 8 inches for a 200 lb. animal. Figure 9 displays the squeeze panels fully open and fully closed.

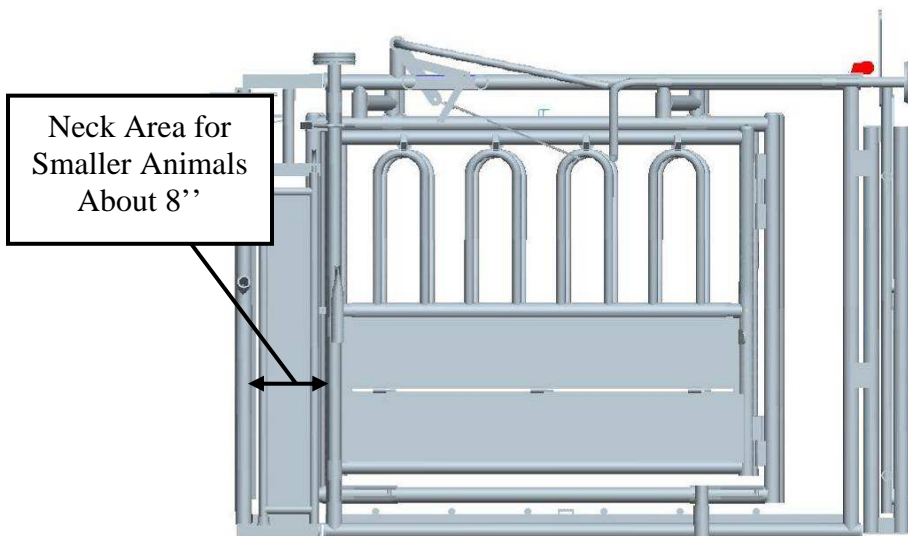


**Figure 9. Squeeze Panels Fully Open and Fully Closed**

The chute has the ability to squeeze down to a dimension of 7 inches and open to 33 inches when the squeeze panels are exactly parallel. The bottom squeeze can be varied in between these dimensions in order to give the squeeze panels a “V” effect or slope effect. The squeeze panels have the ability to move forward 9.5 inches when the squeeze panels are closed all the way. This gives 8 inches of neck area for a small calf. When the squeeze panels are open wide for a larger animal there is 17.5 inches of neck access.



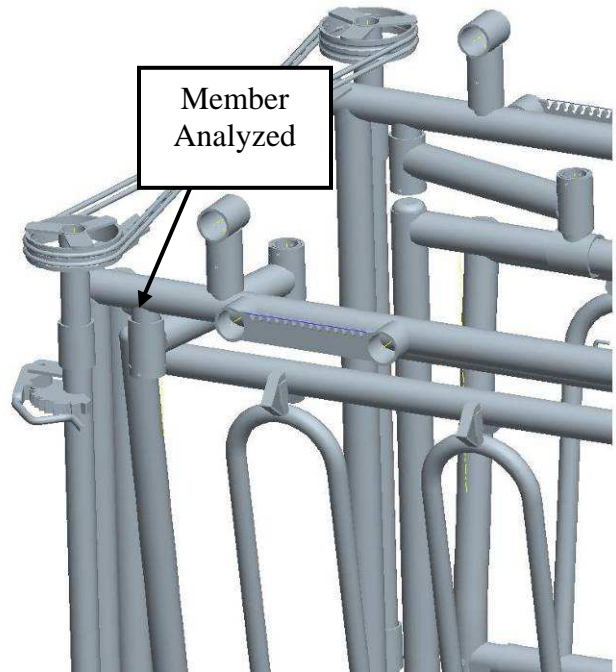
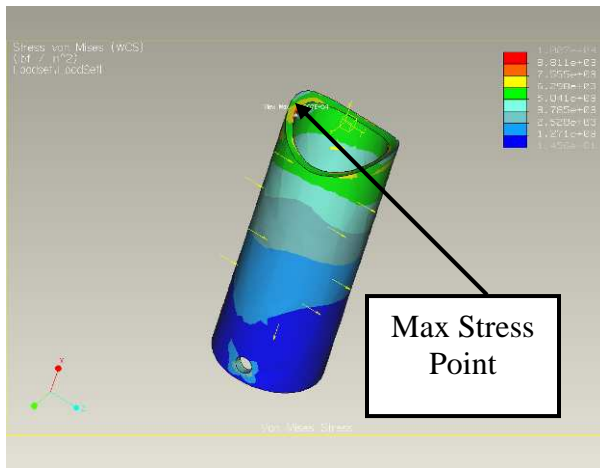
**Figure 10. Larger Animal Neck Access**



**Figure 11. Small Animal Neck Access**

CAS used Pro-Mechanica finite element software to determine the size of materials supporting the squeeze panels. The part expected to fail on the squeeze mechanism is the supports that the top linkages rotate about as shown in Figure 12.





**Figure 12. Finite Element Analysis**

The member in this analysis is 1.5” schedule 40 pipe. There are two 5/16” holes near the bottom of this member. The loads applied were estimated by adding the downward force of a 2000 lb animal in addition to the dead weight of the side panel. The maximum stress on this member is approximately 10,000 psi, which can be seen in figure 12. This gives a factor of safety of approximately 3. This member is more than strong enough for this application.

### Tailgate

In order to meet the desires of a larger range of W-W chute purchasers, CAS has employed multiple tailgate designs. Each tailgate design can be removed by simply removing eight bolts. This will allow each customer to have a choice between tailgates. When CAS approached W-W with this design, they indicated that the number of stocked parts may become a





problem with multiple options for tailgates. W-W suggested that the tailgate options should be limited to only two in order to keep stocked parts low. CAS developed two conceptual tailgates. The first is a guillotine/slider combination. The type of motion of the tailgate can be changed by simple rotating the tailgate and attaching or removing 4 extensions.

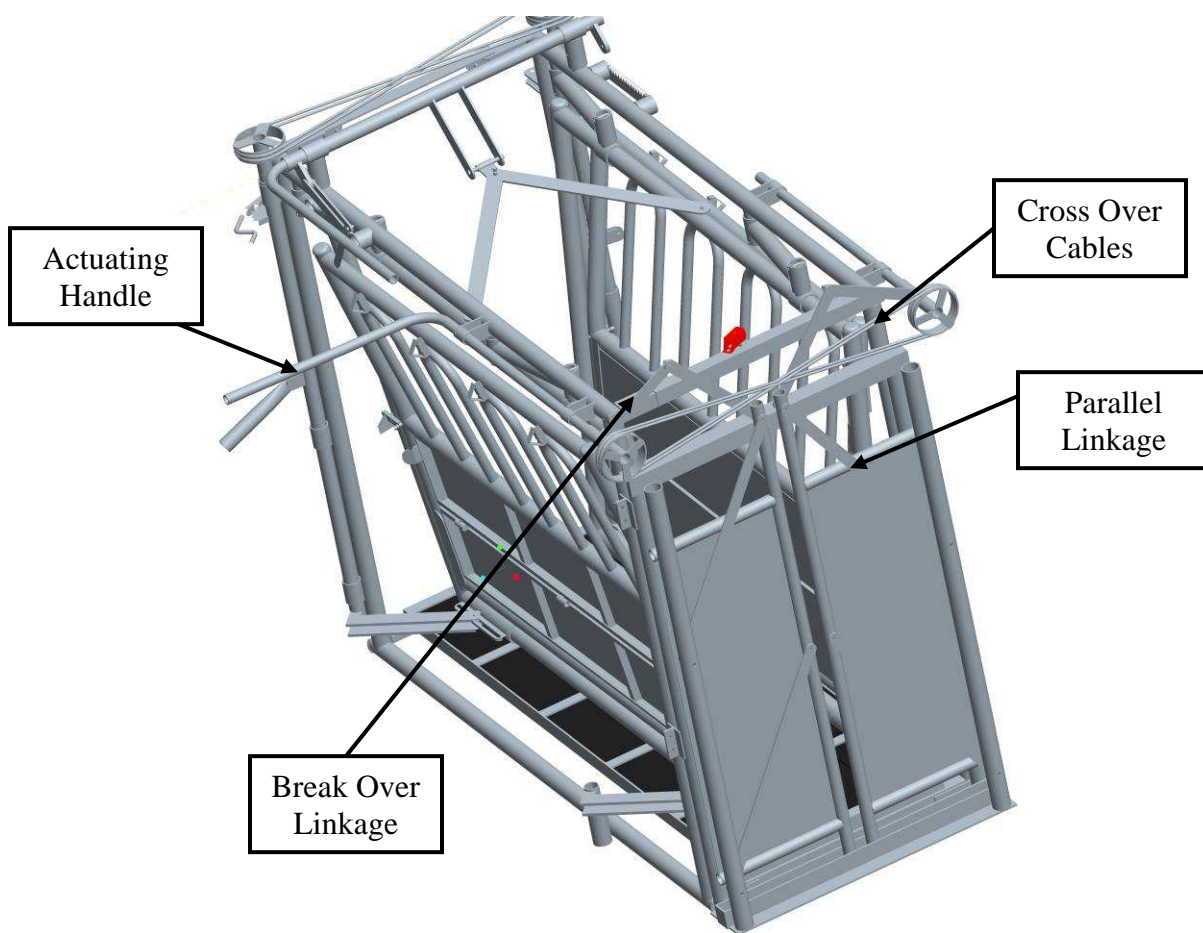
The guillotine/slider combination is a very powerful tool for a cattle operation facing many different tasks when working cattle. The guillotine portion of the gate is very convenient when working a large amount of cattle due to its easy actuation and ease of access. The slider portion of the tailgate is convenient when performing tasks such as artificial insemination.

Figure 13 shows the concept guillotine/slider gate.



**Figure 13. Guillotine/Slider Tail Gate**

The scissor tailgate is the second option designed by CAS. Figure 14 demonstrates the major components involved in the conceptual design. The gate is actuated by pulling down on the actuation handle. The cross-over cables and parallel linkages make the scissor gate travel at a constant speed and position. Due to the placement of the linkages, the scissor gate will stay opened when fully open due to the linkages breaking over center. When the gate is closed, the lever is rotated past center and gravity will naturally close the gates quickly.



**Figure 14. Scissor Tail Gate**

## Floor

CAS has developed a new floor for the concept unit that incorporates Rumber® flooring. Rumber® is a composite material that was developed as a shock absorbing medium in place of such materials as wood or steel. Rumber® has a wide variety of uses such as injection molding, rotational molding, pressing into shapes, and extruding into sheets. Rumber® flooring is desirable in corrosive locations. Rumber® will not rust or deteriorate in the wet and corrosive locations that a chute may encounter. The Rumber® floor will also assist in lowering the noise levels while operating the chute.

In designing the support for the Rumber® flooring, CAS consulted the Rumber® web site [www.rumber.com](http://www.rumber.com). The web site gives suggestions for each application. In the section under livestock trailer flooring, the web site indicated that the spacing between the center supports should be between twelve and fifteen inches. The site also recommended 2 x 2 x ¼ inch angle iron as support members. Table 2 outlines the specifics of the Rumber® flooring.

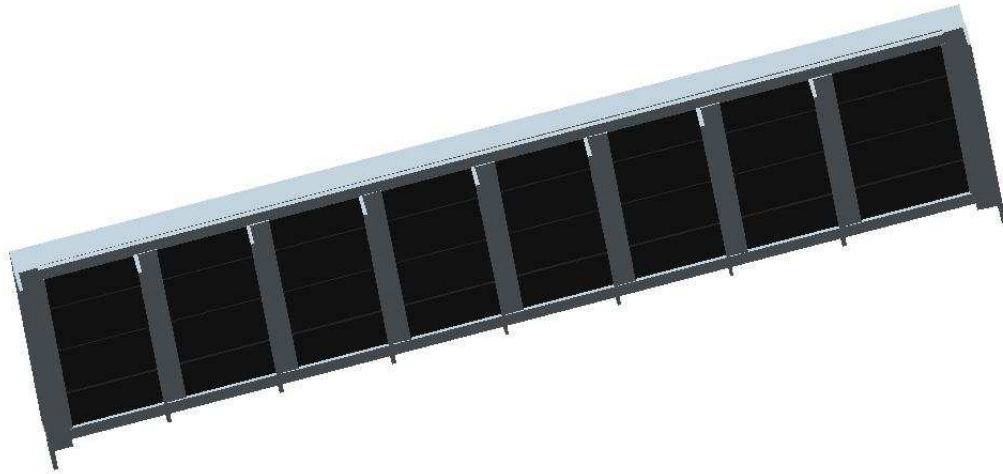
**Table 2. Rumber® Specifications. Source: [www.rumber.com](http://www.rumber.com)**

Test Method	Results		
Density/Specific Gravity	ATSM D 792	g/cc	0.982
Modulus of Elasticity	ATSM D 198	psi	28,000
Compression Strength	ATSM D 143	psi	19,000
Long Span Modulus	ATSM D 4761	psi	17,900
Perpendicular Compression Strength	ATSM D 143	psi	23,000
Ultimate Tensile Strength	ATSM D 143	psi	3,181
Water Absorption	ATSM D 1037	%	0.008
Screw Retention 3/8" lag bolt	ATSM E 588	lb	500
Abrasion Resistance	ATSM D 1037	in	0.02

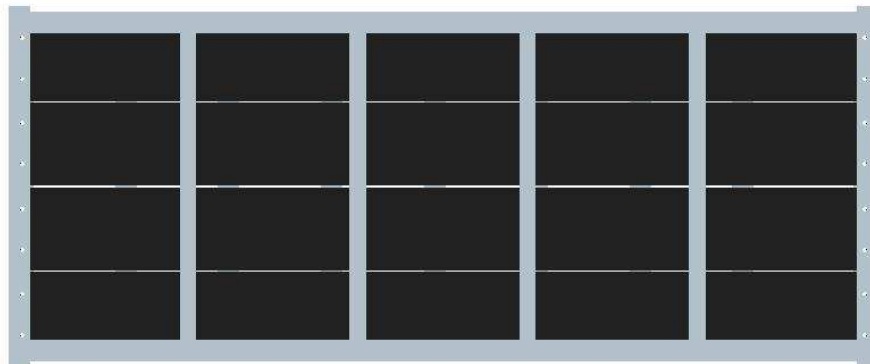
CAS employed a design with ten-inch center spacing with the recommended support steel. While securing the Rumber® to the base support, CAS made a cage of angle iron and 1 flat bar. The cage can be removed in order powder coat the floor by removing bolts. The ten inch



center spacing will insure that the Rumber® does not deflect past a point of plastic deformation. The conceptual floor can be seen in Figure 15 and 16.



**Figure 15. Bottom View of Conceptual Floor**



**Figure 16. Top View of Conceptual Floor**

## **Design Testing**

CAS first tested the chute at Bobby Flores Farms located in Stillwater, Oklahoma. The scissor tailgate was attached to the chute. Four steers and one bull were constrained in the chute. The steers weighed approximately 450 lbs. and the bull weighed approximately 2200 lbs. The



chute adjusted for this wide range of animal size very well. The chute constrained the steers very well but it also opened up enough for the large bull to comfortably enter and exit the chute.

Figure 17 displays one of the first animals tested in the chute. Mr. Flores was very pleased with the operation of the chute. He liked being able to run the headgate, top squeeze, bottom squeeze, and scissor tailgate all from one position and with only one operator.



**Figure 17. First Large Bull Tested in Chute**

This initial test proved to be very successful; however, CAS noticed some aspects of the chute that needed to be corrected. The first was the height of the fold down bars on the side of the chute. The pivot point for the fold down bars was too high on the hip of the 450 lb. steers. This interferes with the branding location on the steers. This is not a problem on larger animals but since most cattle are branded when they are smaller, this problem needed to be corrected. Figure 18 displays the problem.





**Figure 18. Branding Interference Problem**

Following the initial test, CAS lowered the fold down bar pivot point five inches. Jim Kinder of Carney, OK tested the chute next for CAS. He ran approximately forty head of cows through the chute. Mr. Kinder was very pleased with the operation of the chute. The only problem encountered was when the side exit latch “popped” out of the notch. CAS immediately corrected this by making the notch deeper. Figure 19 displays the chute in operation at Kinder Farms.



**Figure 19. Working Cattle at Jim Kinder Farms**

Rolling R3 Ranch located near Guthrie, Oklahoma tested the chute with about 200 head of cows as well. The slider/guillotine combination tailgate was used for this test. Cow herd manager for Rolling R3, Jason Shepard, provided his thoughts on the chute:

- He liked the ability to adjust the top and bottom squeeze independently.
- The two latch system on the head gate is convenient.
- The slider/guillotine combination tailgate worked well.
- He like the ability to control the chute from either side

Figure 20 displays Jason Shepard working cattle with the prototype chute.





**Figure 20. Testing the Chute at Rolling R3**

## **Design Changes**

- Two latch system on headgate instead of three latches
- Notch in the neck access panel
- Lowered fold down bar pivot point five inches

During the construction of the prototype chute, CAS decided to make some design changes. The first change was to use two latches instead of three on the head gate. With the three latch design, CAS felt that there was too much space between the headgate and the headgate stop. This extra space would make too much noise and would allow the animal to move too much when constrained in the headgate. Using a two latch design eliminated this problem and is a simpler design with fewer levers.

CAS redesigned one of the neck access panels with a notch. The change was a must. Without the notch, the handle to open the headgate forward would interfere with the neck access panel and not allow the headgate to fully open. This change was only necessary on one of the neck access panels since the operator can move the panel to the other side for operation. Figure 21 displays the neck access panel with the notch.



**Figure 21. Notch in Neck Access Panel**

Due to interference with branding locations on smaller calves, CAS decided to lower the fold down bar pivot point five inches. The kick panel had to be changed with this new design. The bottom portion of the kick panel was re-built. The bottom portion of the kick panel is five inches shorter than the old design. This proved to be a good design change. The chute was field tested with both configurations and the new design proved to be effective. Figure 22 displays a picture of the new kick panel design.



**Figure 22. New Kick Panel Design**

## **Recommendations**

After constructing and testing the concept chute CAS was able to identify some areas for improvements on any future prototypes.

- Using two linear gears on top squeeze to add resolution
- Lengthen pivot connections for easier assembly
- Make neck panel self catching for easier operation

The first change involves using two linear gears on the top squeeze in order to improve the resolution. By staggering two gears on the rotating top squeeze lever the resolution of the top squeeze will be doubled. In order to implement this type of system a new release and latching mechanism would need to be developed.

Lengthening the pivot connections on the frame by  $\frac{1}{2}$ " will make it easier to assemble the chute due to increased clearance. In order for this change to be made the sub frame will need to be shortened by  $\frac{1}{2}$ " so that the panels will have adequate clearance on the floor. This change



should be monitored carefully as it increases the moment experienced on the pivot connection and torque on the frame.

The final change is that of implementing a self latching mechanism on the neck access panels. Placing self latching mechanisms will make it a quicker process for the operator to close the panel. It also helps put a preload on the latch to insure that an unwanted panel opening will not occur.

## **Cost**

W-W has stressed the importance of cost to CAS since the beginning of the project. In today's manual chute market, there are a number of competitors that build a cost effective chute. If the cost of a manual chute is too high, the customer will simply buy another brand or they will purchase a hydraulic powered chute. Realizing that the manual chute market is such a niche market, CAS has avoided the use of unnecessary material and high manufacturing costs in the design.

After the conceptual design was completed, CAS created a bill of materials in Microsoft Excel. The entire chute is categorized by sub-assemblies. Each part in the sub-assembly is listed below that sub-assembly. Each individual part is labeled with a description, material price, and labor price. With the cost information categorized in this manner, CAS and W-W can analyze the cost very precisely. Table 3 summarizes the manufacturing, labor, and material cost for the fabricating the chute and all of the tailgate options.



**Table 3. Cost Breakdown**

<b>ITEM</b>	<b>TOTAL #</b>	<b>TOTAL COST</b>
Cuts	379	\$94.75
Saddles	32	\$8.00
Punches	138	\$34.50
Welds (in)	1530.5	\$505.76
<b>Total Labor Cost</b>		<b>\$643.01</b>
<b>Total Material Cost</b>		<b>\$536.28</b>
<b>Total Cost of W-W Material</b>		<b>\$906.21</b>

Table 4 summarizes and compares the retail cost of the new chute design chute and the old chute design. CAS used a retail mark up of 120% for the retail cost analysis. The new chute design is more expensive than the old design. CAS feels that this extra cost is justified by the additional features and improved performance of the new chute design. Customers will witness the improved performance of the new chute design and decide that the chute is worth the additional cost. The Excel spreadsheet with the cost information is on the attached compact disc.

**Table 4. Retail Cost Comparison**

<b>ITEM</b>	<b>COST</b>	<b>COMBINATION</b>	<b>RETAIL VALUE (120% mark up)</b>
Basic Chute	\$1,599.53		
Guillotine tailgate	\$74.35	\$1,673.88	\$3,682.54
Combo tailgate	\$221.98	\$1,821.51	\$4,007.32
Scissor tailgate	\$189.64	\$1,789.17	\$3,936.16
Existing Chute	\$1,386.24		\$3,049.73



## Works Cited

- ASAE Standards. 2001. D321.2: Dimensions of Livestock and Poultry.: ASAE
- Daniels, D. D. and D. Schmitz. 2003. Squeeze Chute Apparatus. U.S. Patent No. 6,609,480 B2.
- Grandin, T. Colorado State University. 2000. Restraint of Livestock: March 2000.  
Available at: <http://W-Ww.grandin.com/restrain/intro.rest.html>
- Hubert, D.J., R.L. Huhnke, S.L. Harp. Cattle Handling Safety in Working Facilities. Oklahoma State University Cooperative Extension Service.
- Maghirang, R. G., B. A. Peterson, C. W. Schoonover, M. D. Schrock, and S. D. Vermillion. 2001. Development of an Energy-Absorbing Headgate for Cattle Squeeze Chutes. *Applied Eng. In Agric.* 17 (2): 577-581.
- Pearson, L. B. 1977. Livestock Squeeze Chute. U.S. Patent No. 4,027,629.
- Rumber. 2000. Rumber Specifications Sheet: Available at <http://W-Ww.rumber.com/specs.htm>.  
Accessed December 5, 2005



# Appendix A – Gantt Chart

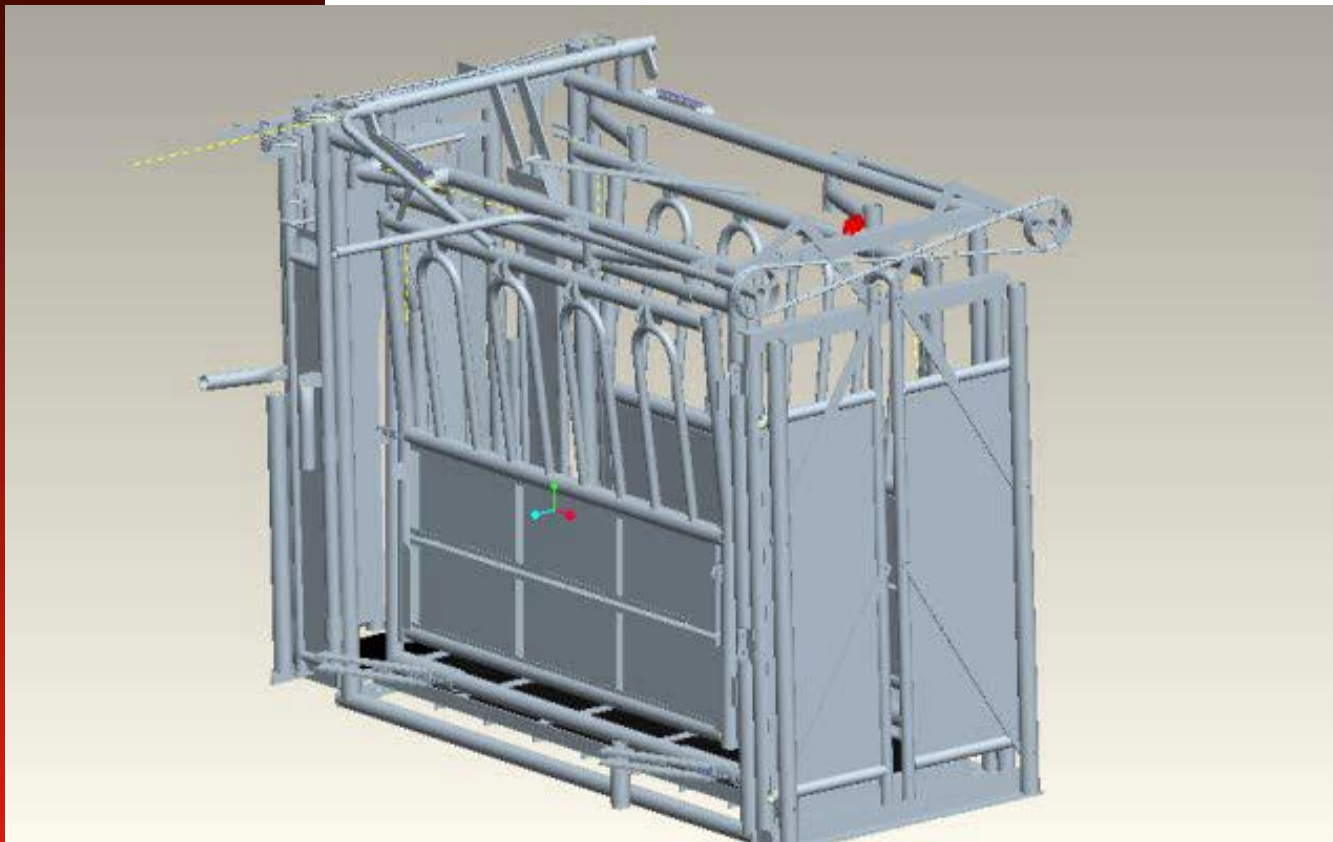








# “BEEFMASTER II”



Joe Biggerstaff

Matt Kilker

William Ryan Haar

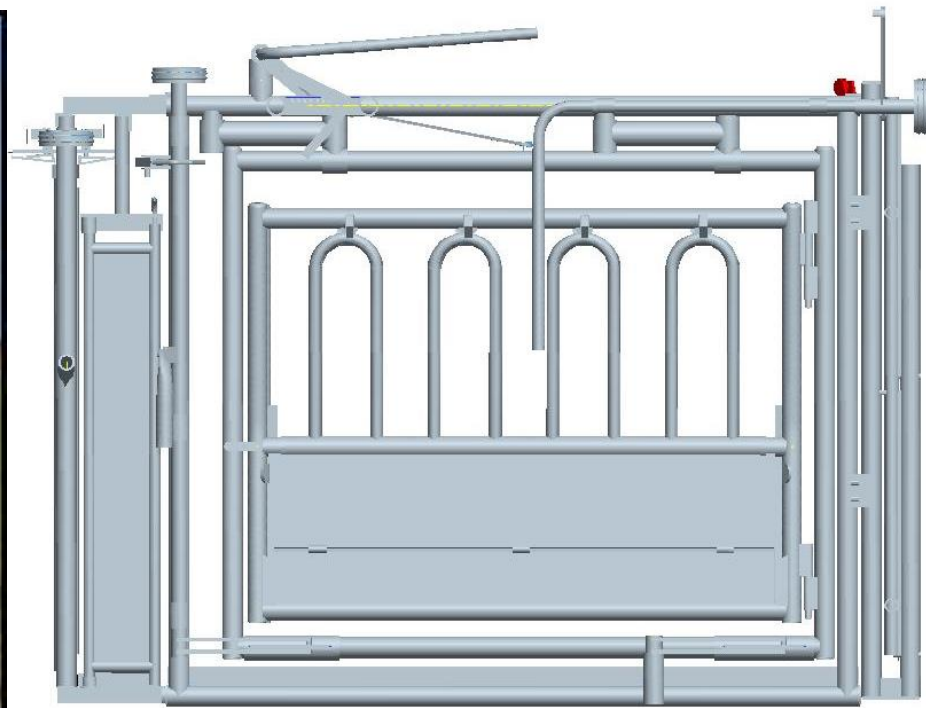
Taylor Miller





# CAS Design Group Assignment

Custom Agricultural Solutions (CAS) has been assigned with the task of improving the design of a manually operated cattle chute.







# Current Design Issues

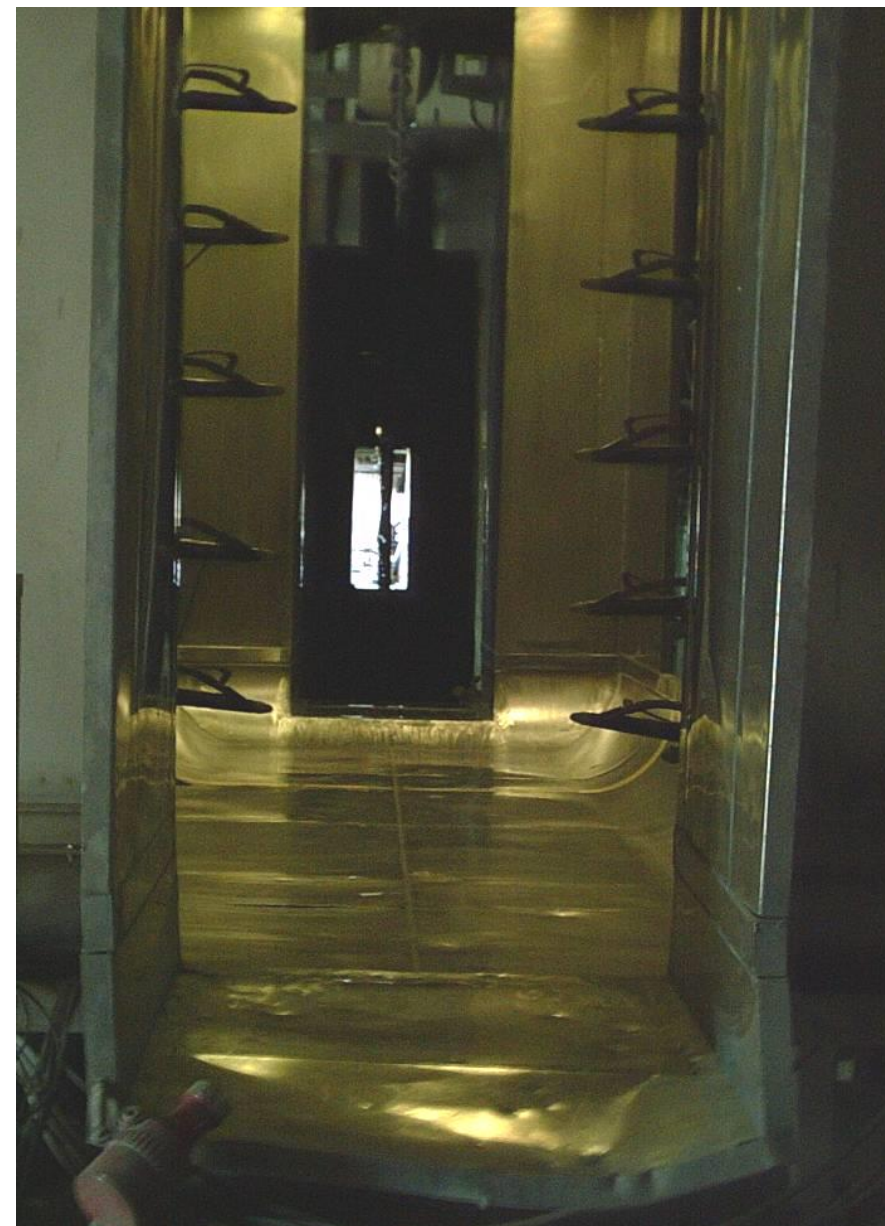
- One Sided Squeeze
- Misalignment of Cattle
- One Sided Control
- Emergency Exit  
Reliability
- Noise Reduction





# Design Criteria

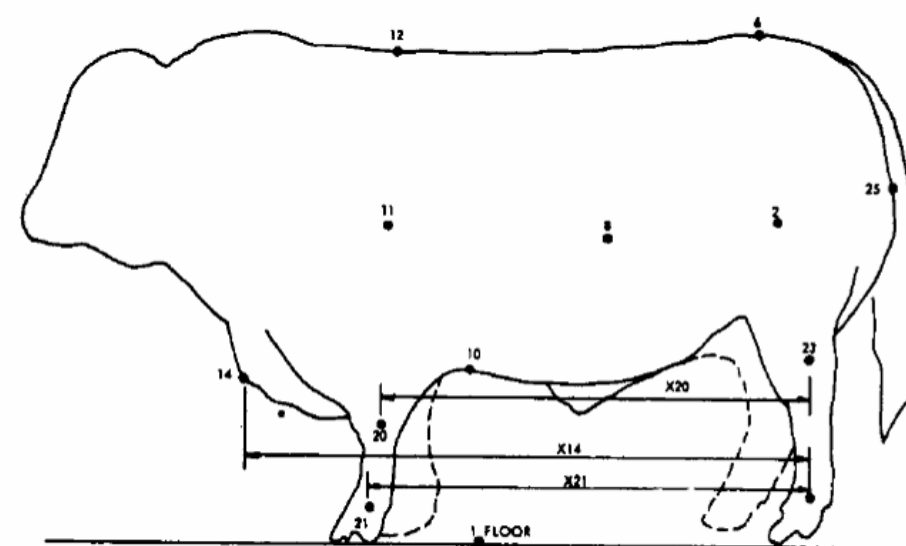
- Fit In Powder Coater
- Maintain Saddled Pipe Practice
- Squeeze From Both Sides
- Maintain Emergency Exit
- Reduce Noise





# Product Research

- Head Gate Forces
- Bovine Size
- Noise
- Solid Barriers (Restrict Vision)
- Non-slip Floor
- Patents



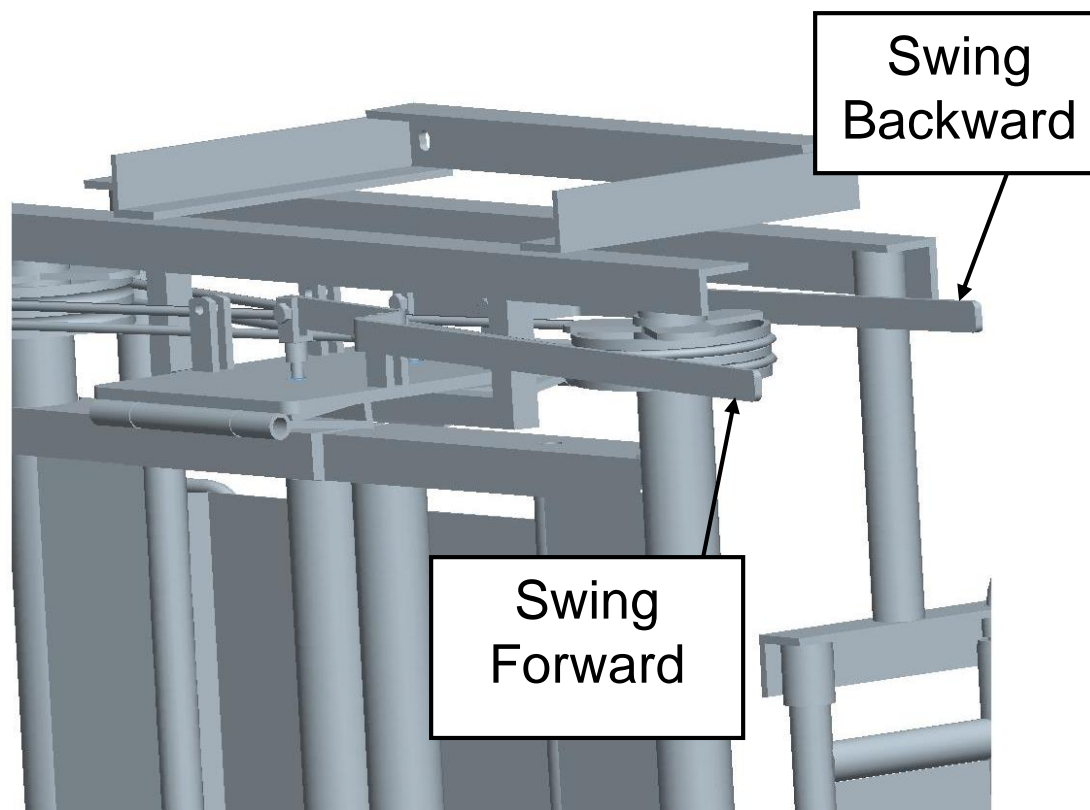




# Head Gate Design

## Two Lever Double Latch

- Front, Back, and Combo Release
- Self Catching

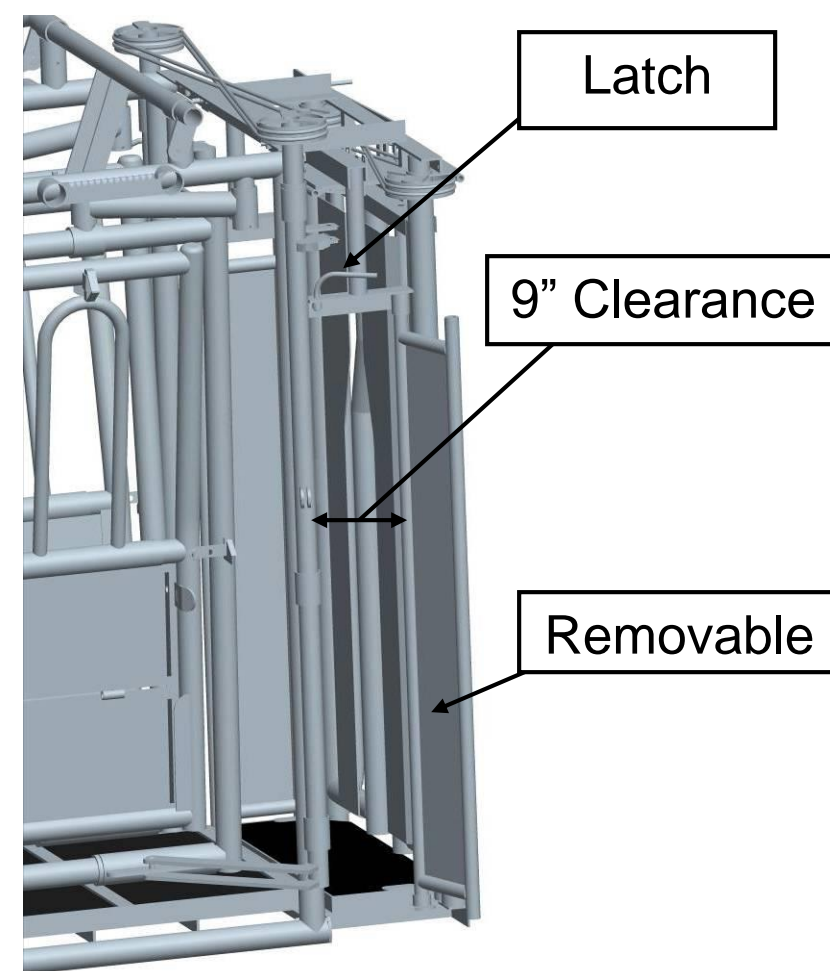




# Head Gate Design

## Neck Access Panel

- Increased Neck Access
- Solid Wall (Vision Impairment)
- Both Sides



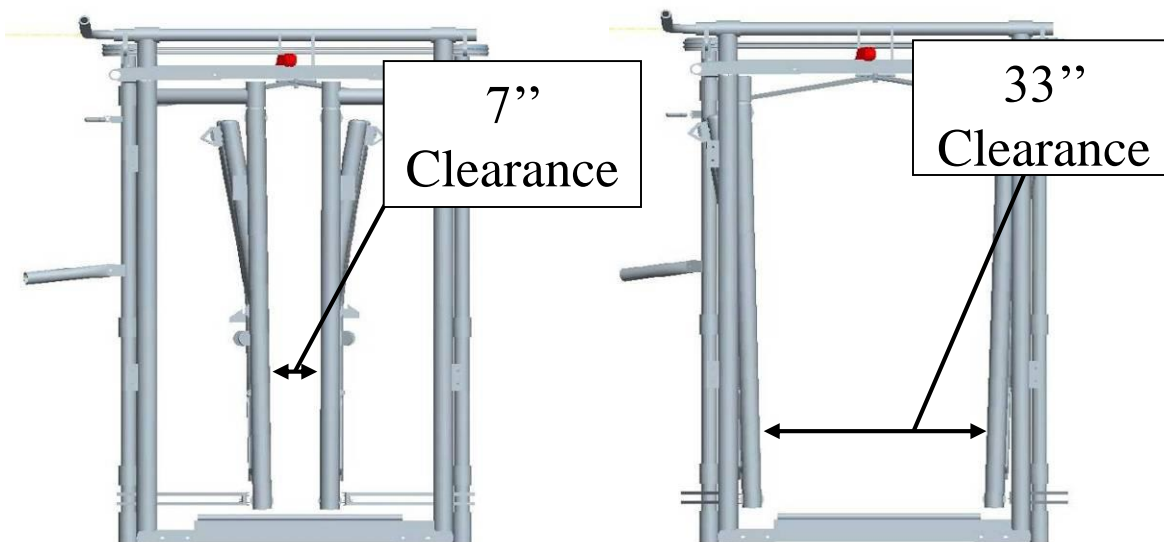




# Squeeze Mechanism Design

## Movement

- Safer Lever Position
- Inward and Forward Movement
- Proper Squeeze Placement

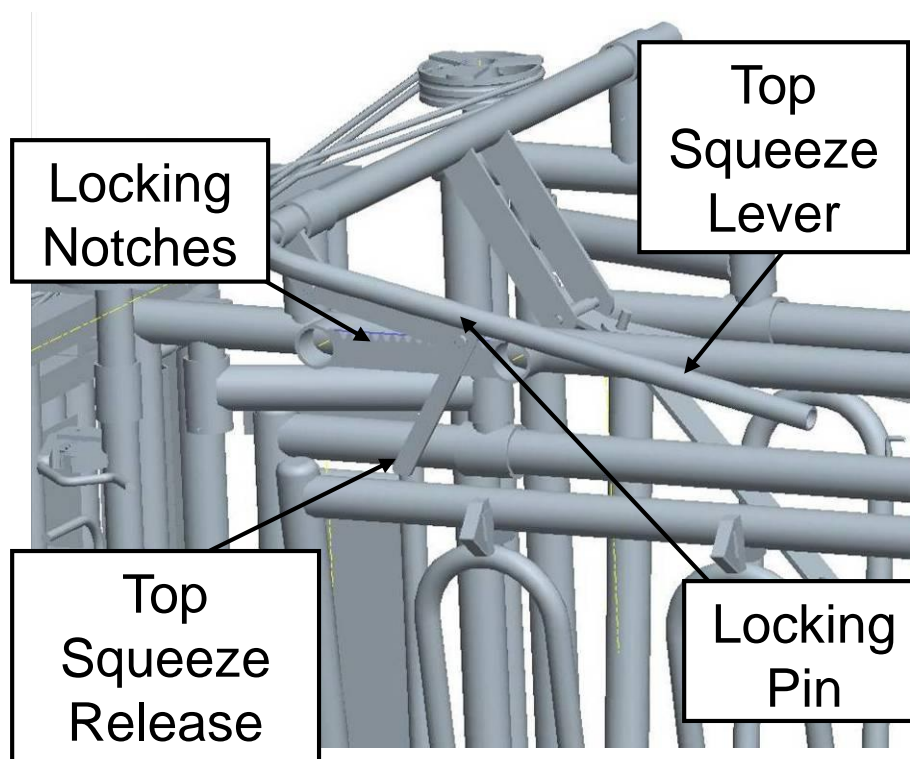




# Squeeze Mechanism Design

## Top Squeeze

- Self-Locking
- Easy Release
- Scissor Linkage







# Squeeze Mechanism Design

## Bottom Squeeze

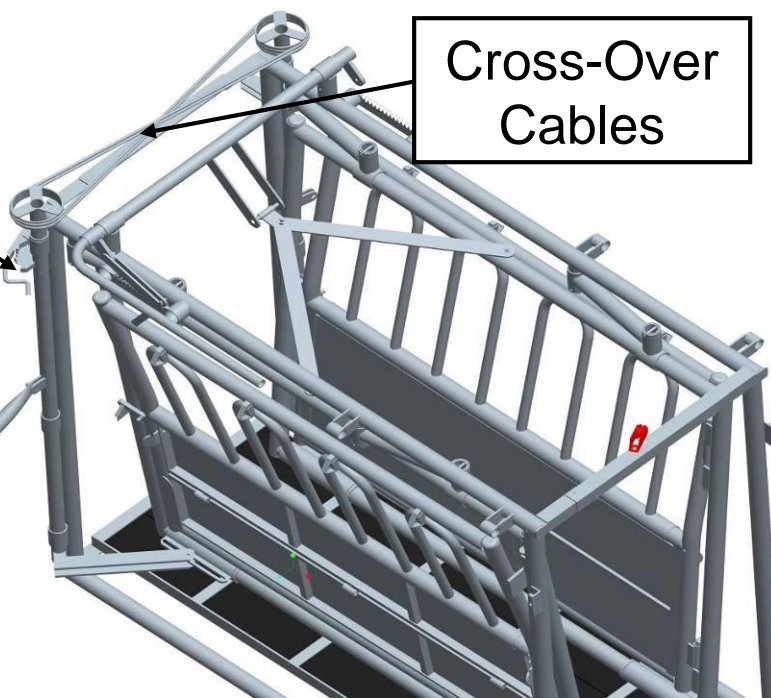
- Proven Parts
- Fold Down Lever
- Self Latching



Bottom Squeeze Release

Cross-Over Cables

Bottom Squeeze Lever





# Tailgate Design

- Ease of Operation
- Multiple Tailgate Designs
- Ease of Attachment



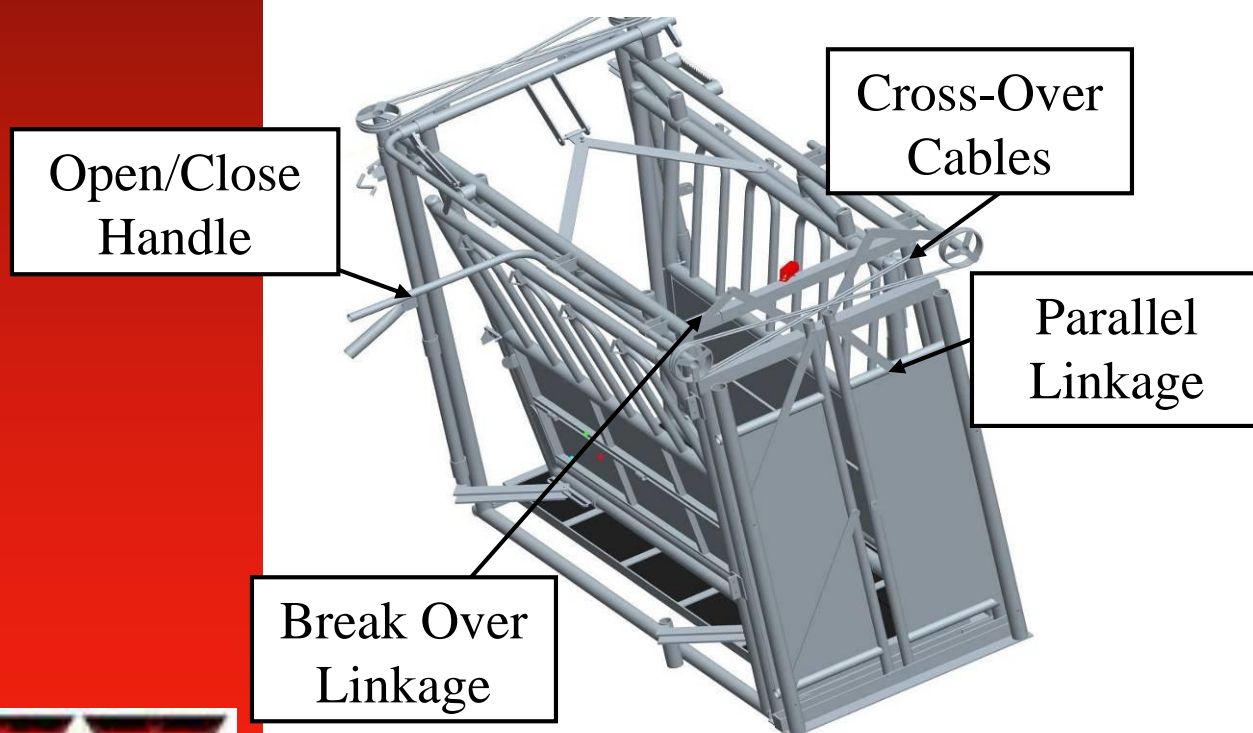




# Tailgate Design

## Scissor Gate

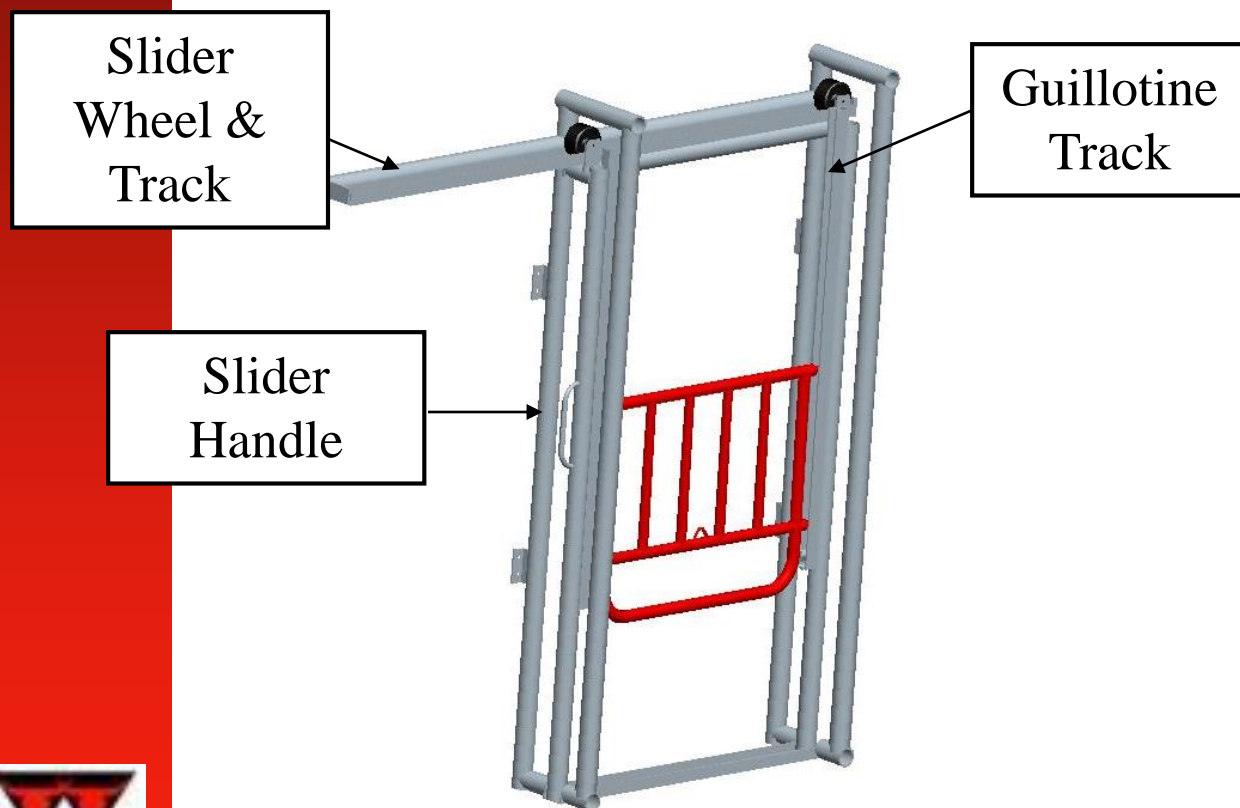
- Gravity Powered
- Self-Locking
- Proven Parts





# Tailgate Design Guillotine/Slider

- Quickly Change Modes
- Multiple Applications
- User Friendly

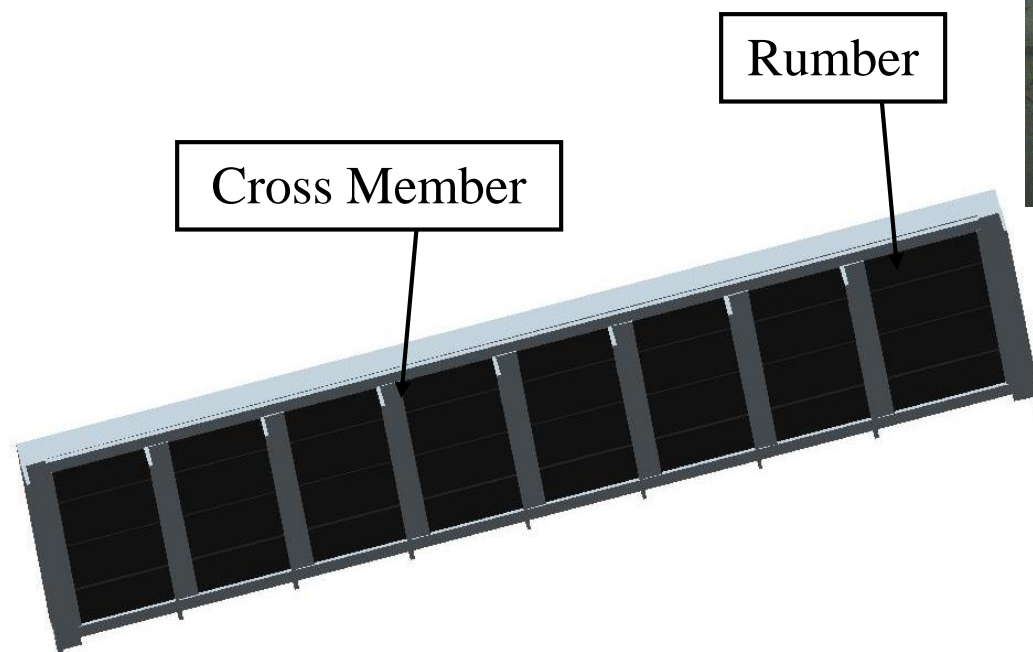






# Floor Design

- Noise Reduction
- No Slip Floor
- Easy Manufacturing







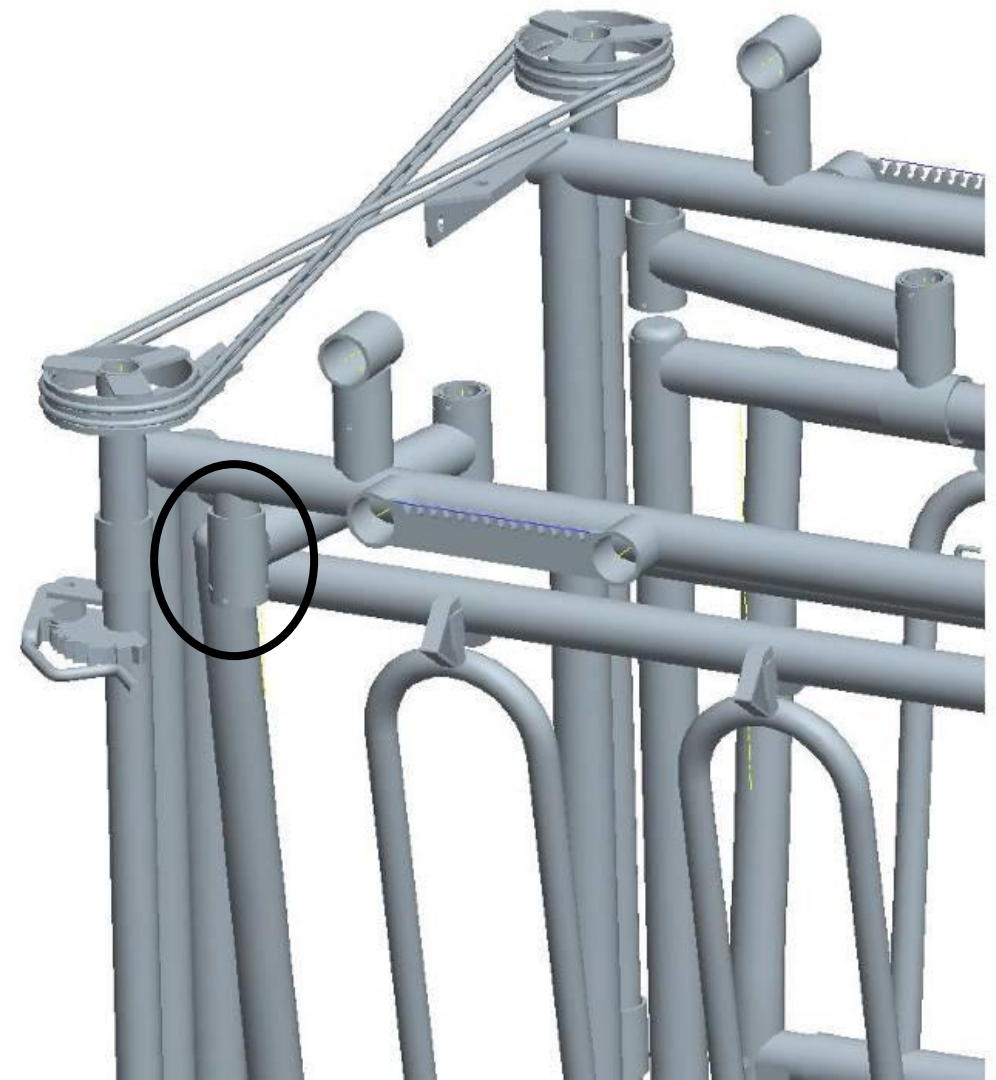
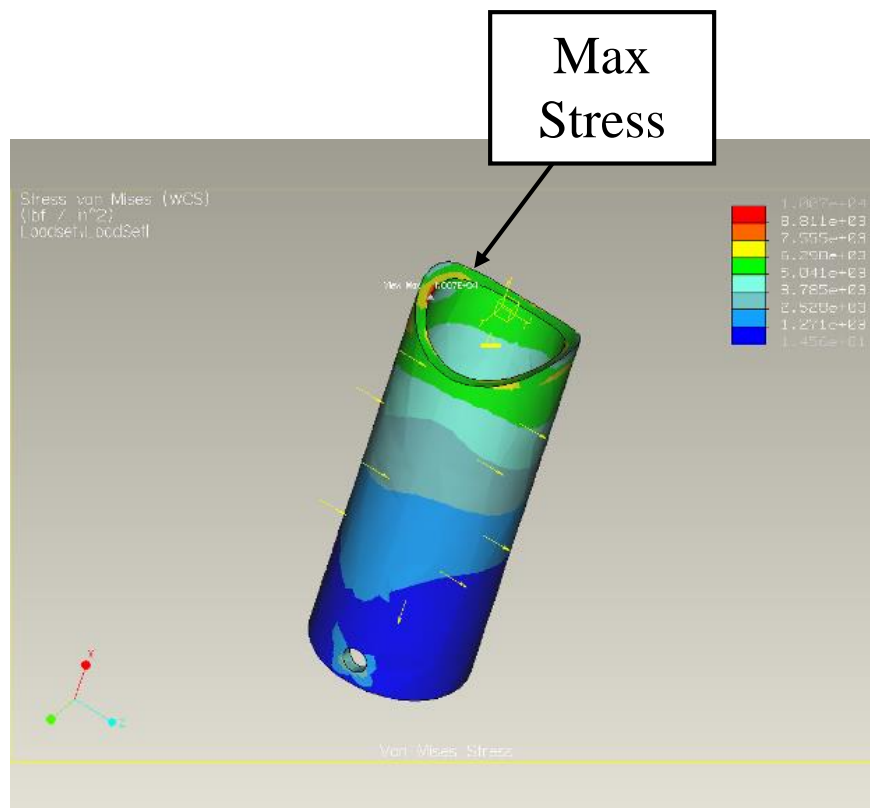
# Proposed Design



# Squeeze Mechanism Design

## FEA Analysis of Critical Parts

- Von Mises Stress
- Deflection





# CUSTOM AGRICULTURAL SOLUTIONS



## Cost Analysis

ITEM	COST	COMBINATION	RETAIL VALUE (120% mark up)
Basic Chute	\$1,599.53		
Guillotine tailgate	\$74.35	\$1,673.88	\$3,682.54
Combo tailgate	\$221.98	\$1,821.51	\$4,007.32
Scissor tailgate	\$189.64	\$1,789.17	\$3,936.16
Existing Chute	\$1,386.24		\$3,049.73

ITEM	TOTAL #	TOTAL COST
Cuts	379	\$94.75
Saddles	32	\$8.00
Punches	138	\$34.50
Welds	1530.5	\$505.76
<b>Total Labor Cost</b>		<b>\$643.01</b>
<b>Total Material Cost</b>		<b>\$536.28</b>
<b>Total Cost of WW Material</b>		<b>\$906.21</b>
<b>Total Cost of Prodotype</b>		<b>\$2,085.50</b>



**PERFORMANCE ENGINEERED**





## Recommendations

- Lengthen squeeze panel pivot pieces
- Use two linear gears on top squeeze for better resolution
- Develop new yoke trailer





# Thank You

- Chuck Vogt, WW Livestock Engineer
- Don Lake, Applications Engineer
- Dr. Paul Weckler, Assistant Professor
- Rolling R3 Ranch
- Jim Kinder Farms
- Clay Burtrum Farms
- Bobby Flores
- Wayne Kiner, BAE Lab Manager





**CUSTOM AGRICULTURAL SOLUTIONS**



Questions?



**PERFORMANCE ENGINEERED**



# Fall Design Report



**Joe Biggerstaff  
William Haar  
Matt Kilker  
Taylor Miller**

**BAE 4012  
December 9, 2005**

# Table of Contents

<b>PROBLEM STATEMENT</b> .....	<b>1</b>
<b>STATEMENT OF WORK</b> .....	<b>1</b>
SQUEEZE MECHANISM ISSUES .....	2
HEADGATE ISSUES .....	3
TAIL GATE ISSUES .....	3
MISCELLANEOUS ISSUES.....	4
<b>PATENT AND LITERATURE SEARCH</b> .....	<b>7</b>
PATENTS.....	7
LITERATURE .....	8
<b>DESIGN SPECIFICATIONS</b> .....	<b>9</b>
<b>DESIGN CONCEPT</b> .....	<b>10</b>
HEADGATE.....	10
SQUEEZE MECHANISM .....	12
<i>Squeeze Mechanism Dimensions and Further Analysis</i> .....	16
TAILGATE .....	19
FLOOR .....	22
<b>COST</b> .....	<b>23</b>
<b>WORKS CITED</b> .....	<b>25</b>



## Problem Statement

W-W Livestock Systems has been a competitive manufacturer of livestock equipment since 1945. They have produced a quality manually operated cattle restraining chute for many years. However, their current design the “BEEFMASTER” needs updated in order to stay competitive in today’s market. Custom Agricultural Designs (CAS) accepted the task of improving the design of a manually operated cattle chute while considering the manufacturing and design constraints set forth by W-W livestock systems. The design must improve ease of operation and reduce stress on the animal.



**Figure 1. W-W Livestock System "BEEFMASTER" Current Chute Design**

## Statement of Work

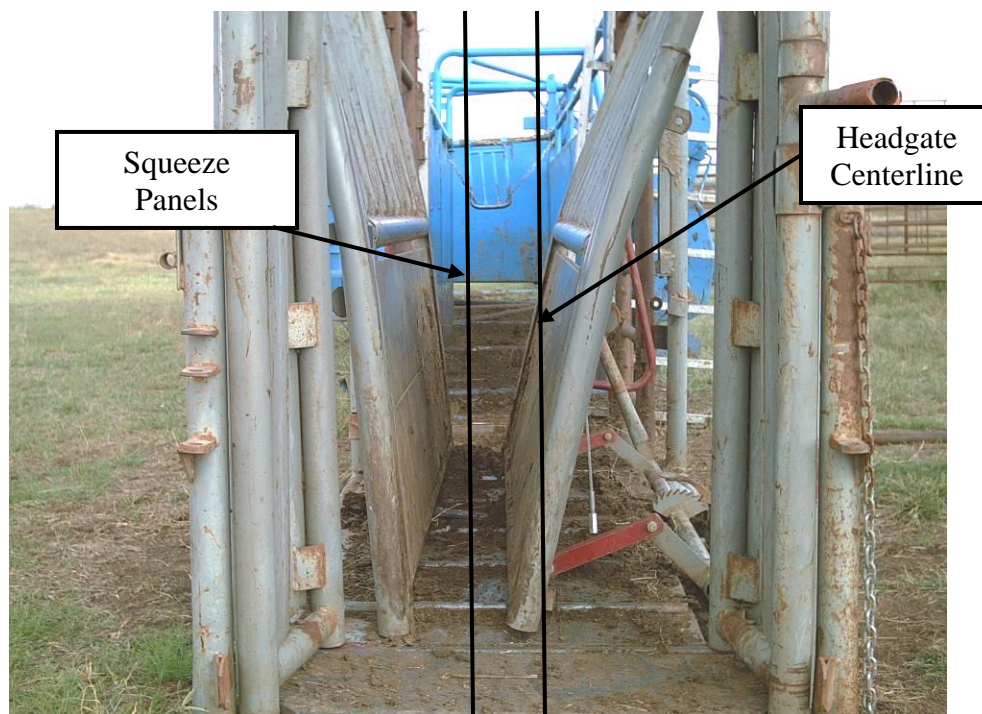
W-W met with CAS in September to establish the design objectives for a new manual chute design. They have asked CAS to develop new ideas in compliance with their design constraints in order to help meet their objective of staying competitive in the marketplace. CAS



will begin the process by investigating problems encountered by owners of current W-W chutes. CAS will then generate design concepts, model these concepts, and build a prototype unit for testing and further evaluation by W-W personnel.

## Squeeze Mechanism Issues

The squeeze mechanism is a primary concern of the current design. W-W expressed concern over their current chutes inability to squeeze from both sides. Currently their chute squeezes from only one side which causes the centerline of the squeeze to be out of line with the centerline of the head gate. This causes misalignment of the spine of the animal, being ultimately detrimental to the health of the animal as shown in Figure 2.



**Figure 2. Misalignment Due to Single Squeeze**

The misalignment of the squeeze panels is not the only aspect of the chute that causes health problems for the animal. The squeeze panels produce a significant amount of noise during operation. The mechanism that attaches the squeeze panels to the floor is the primary cause of

the excessive noise. Loud noise increases the stress on the animal during treatment which increases the likelihood of sickness. Noise from the chute must be reduced or preferably eliminated in the prototype unit.

The final concern addressed is the operation of the chute needs to be easy for any operator from one position. It would be optimal for the chute to be able to be controlled from the left or right side of the chute. The squeeze must also retain the emergency exit or side exit which can be easily opened by the operator. Increasing the angle at which the emergency exit can open should be considered.

## Headgate Issues

W-W Livestock systems asked CAS to improve the latching mechanism of the headgate, as the current design requires constant adjustment to work correctly. The current latch is designed to enable the operator to swing the headgate back to the catch position without pulling the latch lever. However, the back latch must be aligned in a very precise location to catch the headgate properly. The spring that returns the back latch must be adjusted properly in order for the latch to return to its correct position. W-W also requested that the operating controls be placed in such a manner that the chute may be operated from the left or right side. W-W would like for CAS to redesign the latching mechanism in order to increase the reliability of the latch and the ease of manufacturing.

## Tail Gate Issues

The tailgate is a great area of concern for W-W. Weaker operators complain that they cannot actuate the tailgate. W-W needs a tailgate that can be actuated by anyone from small children to grown men. However, the tailgate must be structurally sound due to the loads



imposed on it during operation. When developing the structure of the concept tailgates, CAS should explore ways to reduce noise that can be attributed to metal on metal contact.

## Miscellaneous Issues

W-W is addressing the issue of noisy operation in cattle equipment. In order to reduce the noise levels while working cattle, W-W wants to incorporate a rumbar floor. They suggested designing a new floor support that will allow the steel C-channel to be replaced by common sized rumbar. The cross members must be close enough to support the rumbar and restrict the rumbar from deflection. Noise will be reduced by reducing the number of metal on metal contacts. The use of poly urethane bushings along with rubber on all contacting surfaces will be implemented.

This particular model of chute uses a special yoke trailer for transport. The design of the trailer simplifies transportation of the chute from one location to the next. Changes to the yoke trailer are needed in order to accommodate the concept unit. The trailer must balance the chute properly. Height of the chute on the trailer is also a consideration so that clearance does not become an issue.

## Testing and Observations

In order to find solutions for the problems with the current W-W chute, CAS interviewed ranchers from all over the state of Oklahoma. These ranchers expressed many of the same concerns as W-W. One aspect that CAS quickly learned was that every rancher preferred something different. Ranchers with large cattle breeds such as Simmental and Chianina breeds complain about the small size of the chute. Ranchers with smaller breeds indicate that the size is fine. Some ranchers like a guillotine gate, some a slider, some a scissor-type and so on.





CAS went to Rolling-R3 Ranch to work cattle and witness the problems of the, “BEEFMASTER” firsthand. CAS met with Jason Shepard, the cow herd manager for Rolling-R3 Ranch. At the meeting, the team began by discussing the changes which W-W had already suggested. After all the aspects already covered between CAS and W-W were discussed in detail, Mr. Shepard began to explain, and show the team members the problems with the chute which he had encountered in his six years of experience with the “BEEFMASTER” manual chute.

Eleven areas of concern were pointed out by Mr. Shepard:

- The rubber floor in the headgate- The two rubber planks in the head gate raise up out of placement from time to time due to material build up and cattle impact. Once the pieces are out of place, the head gate catches on the floor and restricts movement resulting in failure to open and close the head gate.
- The latching mechanism on the headgate latch- The mechanism uses a round bar with an ear on the end to restrict the latch from moving upward; hence, locking the headgate shut. The round bar must move laterally through two sleeves. The bar catches in the sleeves and does not move freely, causing difficulties in unlocking the headgate latch.
- Tailgate- The guillotine type tailgate is in the way when using the palpation gate and performing artificial insemination on cattle. A slider type tailgate would be more desirable for the applications used by R3 Ranch.
- Latches on the kick panels- The nuts which attach the pull cables to the latches back off and the cables come unscrewed.



- Emergency Exit Latch- The latch on the exit is not reliable. Nearly 25% of the time, the gate does not latch; therefore, the operator must go around the chute and manually push the gate shut.
- Emergency Exit Gate- The gate does not swing open on its own. The gate must be pulled or pushed open manually, which is very inconvenient for the operator.
- Bottom width Adjustment- The movement of the squeeze panel becomes very restricted after time due to material build up and steel rust.
- Squeeze Pull Handle- The handle is very hazardous to tall operators due to the low placement. The handle height should be adjustable to accommodate all sizes of operators.
- Releasing the Squeeze- In the situation of downed cattle, the release of the squeeze is very difficult due to the low resolution of the gearing on the latch. In some cases, releasing requires more than one person; which is very undesirable.
- Transporting the Chute- The current design on the yoke trailer requires a bar to be placed all the way across the back of the chute. When placing the chute in work areas, this is very inconvenient. The chute must be dropped forward of the desired working location and moved back into place.

After Mr. Shepard had completed his discussion, the team worked a few 1500 lb Angus Cows and encountered many of the problems described. This experience gave CAS a much better understanding of the problems. With this knowledge, CAS can design a chute more efficiently.

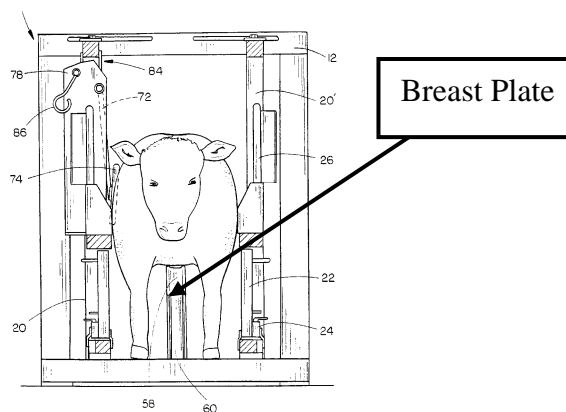


## Patent and Literature Search

CAS has done extensive research involving the development of the new W-W concept chute. We determined that the research must involve patent and article research as well as the communication with operators of the current W-W chute. The summary of the information gathered will help guide the design team in the development of the concept unit.

### Patents

Many patents involve the design of cattle chutes; however, most are out of date and will not affect the prototype design. The more recent patents concern all of the working entities of hydraulic chutes. United States Patent 4,027,629 involves a design that appears useful. This patent is from June 7, 1977 and is outdated. One patent of concern to CAS is United States Patent 6,609,480 B2, referring to the use of an abdomen support to reduce the incident of bovine going down in the chute. The abdomen support, as shown in Figure 3, is referred to as a breast plate. A breast plate, used to keep the bovine elevated while in the chute, was found to be a very interesting idea. The use of the breast plate will not allow cattle to drop all the way down in the chute; thus solving the problem of restricted release of the squeeze mechanism. This is the only attachment that we are considering adding to the chute that poses an infringement problem.



**Figure 3. Breast Plate Patent**

## Literature

CAS found little information in the literature review or testing of cattle chutes. However, Maghirange (2001) wrote an interesting paper on the testing of a head gate. The head gate is a very critical aspect in the design of a cattle chute. By visiting with local ranchers and through CAS's experiences at Rolling-R3, the team determined that the headgate is crucial to the design of the chute. Cattle can only see out of the headgate area when entering the chute. Therefore, cattle view the headgate as their only exit and will lunge or try to run out of the head gate. This leads to the concern that the structure supporting the head gate is subject to large forces.

The purpose of the experiment conducted by Maghirang (2001) was to develop an energy-absorbing headgate. The article indicates that the headgate inflicts bruises on 2 to 8% of cattle that are restrained in a chute. In some cases, the headgate can kill cattle with excessive pressure on the carotid arteries. Many newer head gate designs use a metal gate that moves transverse to restrain the head of the animal. The headgate is made entirely of mild steel and all of the contacting surfaces are steel on steel. This results in a sudden stop when the animal hits the headgate. This rapid change in momentum is detrimental to the animal's health.

Maghirang (2001) began by using load cells to measure the forces induced on the headgate with an energy-absorbing device. Heifers ranging from 792 to 1012 lb. were used in the experiment. The measured impact forces ranged from 360 to 2900 lb. The energy absorbing headgate absorbed 19 to 46% of the energy; resulting in less strain on the animal. After reading this article, the design team will pursue a way to have an energy absorbing device on the headgate. This will cause less stress on the animal and the stresses in the material will not be as large.





Dr. Temple Grandin, assistant professor at Colorado State University, published articles on animal welfare and restraint. Grandin (2000) discusses many significant points to consider when restraining animals. She indicates that cattle become excited and agitated in a squeeze chute and will have lower weight gains and are more likely to have dark cutting meat.

Dr. Temple gives suggestions on chute design:

- Encourage slow steady motion to calm an animal, as opposed to sudden jerky motion.
- Engineer equipment to minimize noise
- Use solid barriers on sides so that the only exit the animal sees is the headgate
- Use optimum pressure. Provide enough to make the animal feel restrained but do not apply so much pressure that the animal is inflicted with pain.
- Provide non-slip floors

## **Design Specifications**

W-W told CAS that they would entertain any design concepts. However, if the following criteria are not met in the concept design, the design will not be implemented. W-W indicated that these criteria are very strict and cannot deviate.

- Break down the chute into components. The components must be small enough to fit into their powder coating booth which has an opening of approximately (36" X 120").
- Saddle pipe to meet their current practices.
- Squeeze from both sides.
- Maintain emergency or side exit.
- Reduce noise.



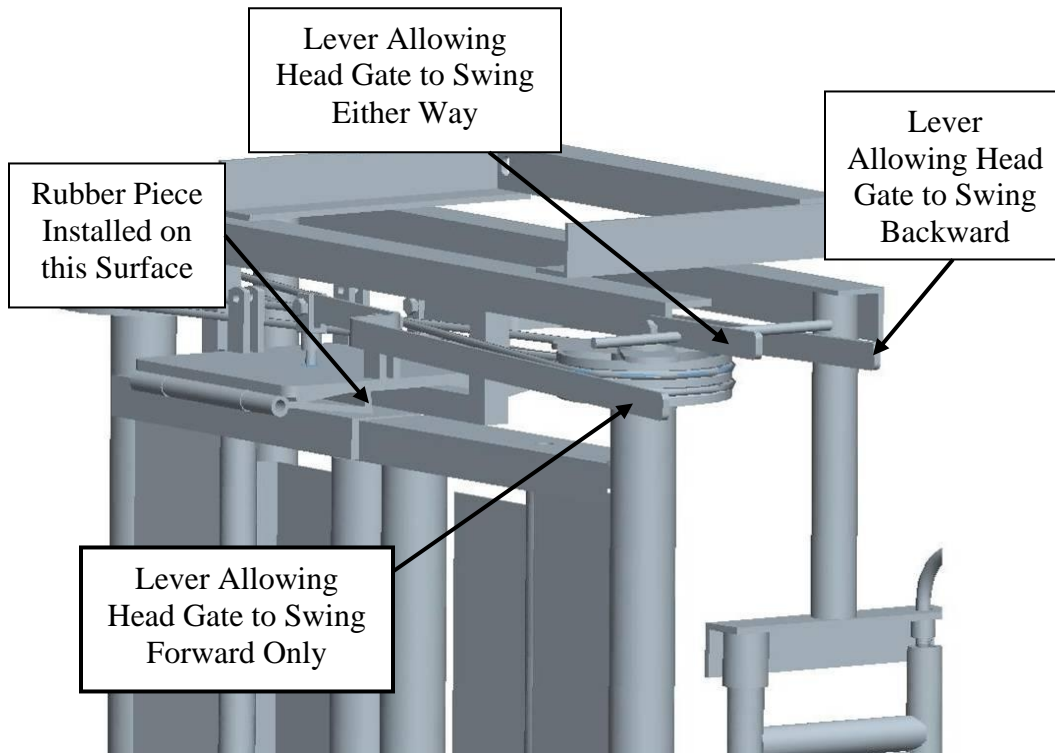
## Design Concept

CAS has designed a livestock chute that is more versatile than any other chute on the market. With the proposed design, the operator will be able to run a 1200 lb. cow through the chute and then be able to run a 200 lb. calf directly after that cow and not have to stop to make adjustments. With a design this versatile and safe, the operator will save a significant amount of time and labor. The controls for this chute can be installed on either the left or right side of the chute depending on the operator's preference. All controls are accessible while the operator stands in one place, and are placed in a safe position.

### Headgate

To obtain a reliable headgate latching mechanism, CAS has designed a three lever double latching system. The design has a front and rear latch which restricts the headgate panels from forward or backward motion. The latches are spring actuated to insure that each latch closes without operator input. Each latch can act independently with a selected lever. Figure 4 shows the positions of each latch while the head gate is restricted to forward motion. This design allows the latch to have a significant amount of downward motion to secure the headgate which solves the problem with the current W-W headgate latch design. To maintain the ability of the headgate to actuate in either direction with the operation of one lever, a third lever is used to actuate the front and rear levers simultaneously. As illustrated in Figure 4, this design has a great deal of versatility allowing the operator to work quickly and efficiently.



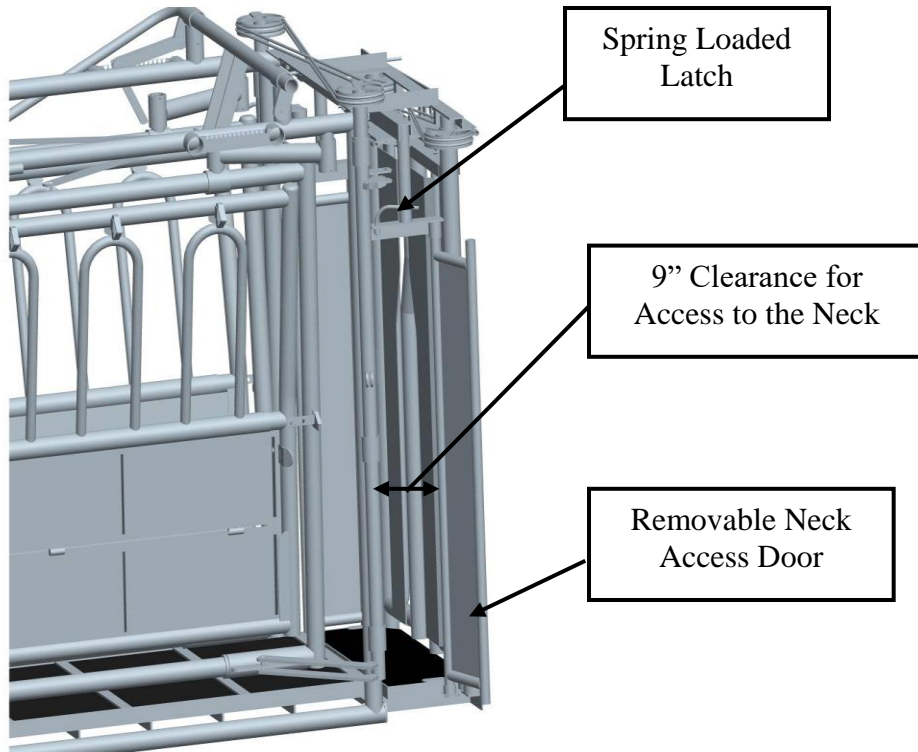


**Figure 4. Headgate Lever Detail**

CAS utilized experimental data from Maghirang (2001) for the stress analysis on the vital components of the headgate. CAS used the data to size the pins and structure that support the members absorbing the force of an animal hitting the head gate. In order to absorb some of the energy of an animal hitting the head gate, rubber pieces will be installed on the contact surfaces of the head gate as shown in Figure 4. This will reduce the impact force on the animal and result in less stress and bruising.

When consulting with many chute operators, a primary area of concern on the head gate was access to the neck of the bovine. The neck area is a location where large amounts of medications are administered. CAS has developed a removable neck access door that swings open or can be removed in order to address this issue. The neck access door of the head gates are easily opened by pulling on a spring loaded latch and swinging the gate forward toward the front of the head gate as illustrated in Figure 4. The neck access door can then be removed if

desired by pulling the gate out of the bottom pivot and then the top pivot. Nine inches of room allows operators the needed area needed for application of various medications. When medications have been administered the door is easily closed and latched by the spring loaded latch.



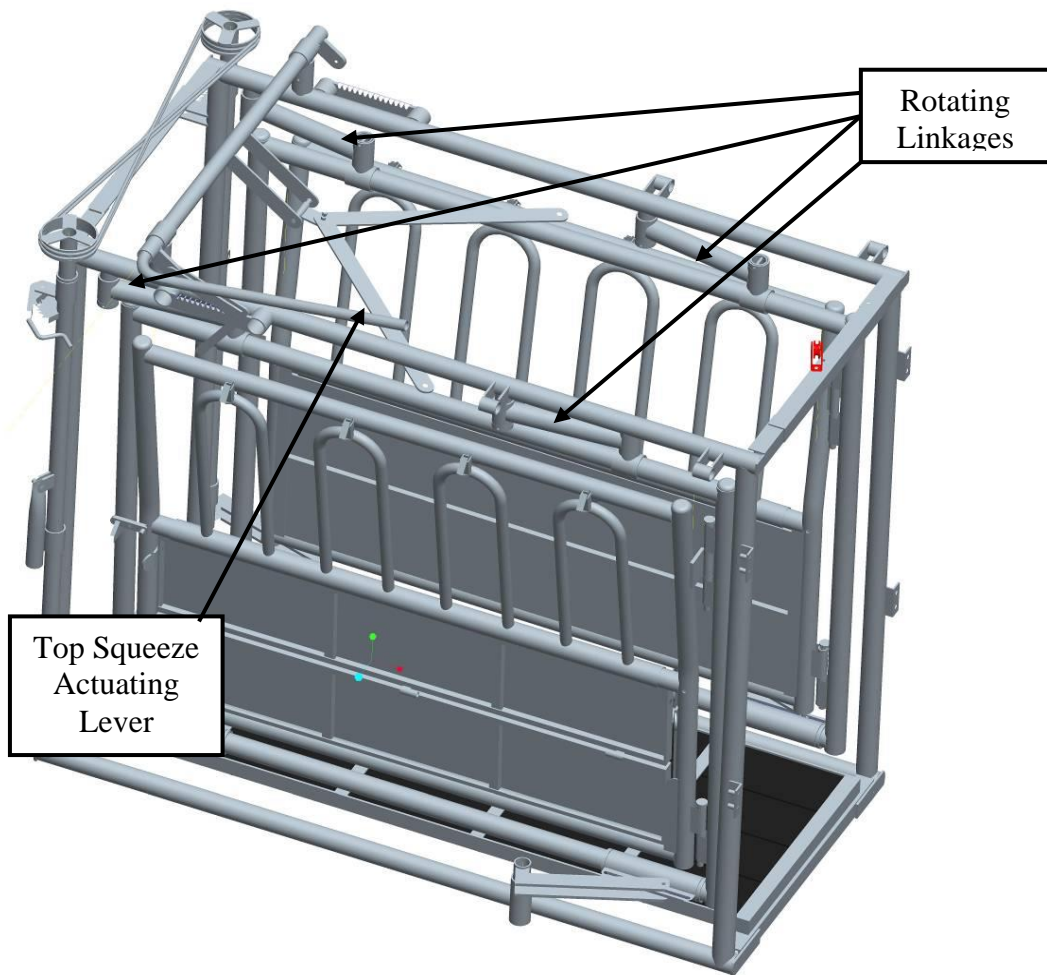
**Figure 5. Neck Access Door**

### Squeeze Mechanism

In order to meet the design specifications of squeezing from both sides, CAS has employed a design which moves inward and forward. By mounting each of the squeeze panels to a pair of linkages that rotate the squeeze panels toward one another equally, both sides squeeze together. This provides a symmetrical squeezing action. Since the squeeze panels are constrained to a circular motion, the squeeze moves forward as well when the squeeze is actuated as shown



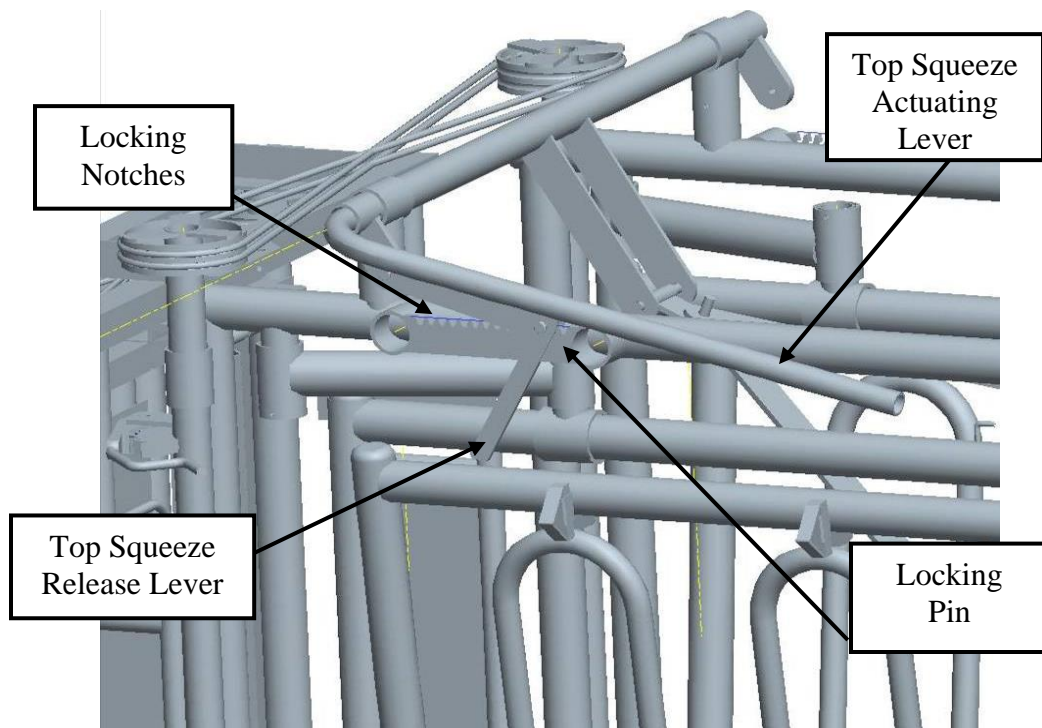
in Figure 6. The squeezing action of this design is similar to the design of United States Patent



**Figure 6. Symmetrical Squeeze**

The squeeze is divided into a top squeeze portion and a bottom squeeze portion. Each respective squeeze is actuated by simply pulling a lever. If the operator so desires, he or she can pull the lever that actuates the top portion of the squeeze and the bottom follows accordingly. In this mode, the squeeze panels move together nearly parallel and the operator can ignore the bottom squeeze portion.

The lever for the top squeeze is 34 inches long which will give a weaker operator enough mechanical advantage to squeeze the animal tighter than the current design. The lever rotates approximately 75 degrees from all the way closed to fully open. The squeeze is locked in place by a piece of strap that is linked to the rotating squeeze axle. This piece of strap locks against a set of notches as shown in Figure 7. With this many degrees of rotation and the fine pitch of the locking notches, the operator has a fine tuned adjustment on the squeeze of the animal. When the operator wants to release the animal, they simply pull the squeeze lever downward, lift the lever on the locking strap, and the squeeze releases.

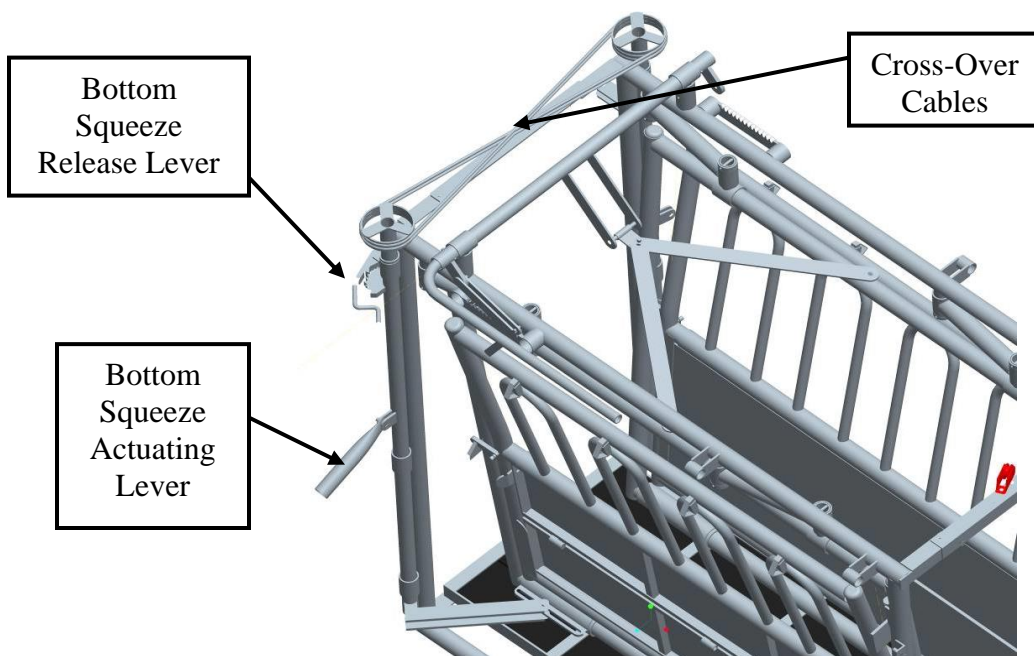


**Figure 7. Details of Top Squeeze Mechanism**

With this type of squeezing motion, the narrower the squeeze, the farther forward the squeeze panels are positioned toward the head of the animal. This feature solves the problem of the squeeze panels only restraining a small portion of the rear of a small calf while keeping the spine aligned with the central axis of the chute. When a smaller calf is in the chute, the squeeze

panels will restrain more of the calf's body as compared to the current W-W design. When a larger animal is in the chute, the squeeze panels will be further back which improves neck access where many vaccinations are administered.

The ability to conveniently and independently adjust the bottom portion of the squeeze is crucial. The CAS bottom squeeze design is a first for manually operated chutes. With most manual chutes on the market, the bottom squeeze cannot be adjusted once an animal is in the chute. The bottom squeeze on this chute is operated independently from the main top squeeze by simply actuating a lever as shown in Figure 8. This lever is hinged on a bolt and will conveniently fold out of the way while not in use.



**Figure 8. Bottom Squeeze Details**

When the top squeeze is actuated, the bottom squeeze is linked so that the squeeze panels are parallel. Once the operator has the animal squeezed, they can use the bottom squeeze lever to obtain more squeeze on the bottom if they so desire. Operators like to make the bottom narrower

than the top because this provides a lifting action on the animal and will prevent the animal from “choking down.” The operator also has the option to initially set the bottom squeeze and leave it when restraining the animal. A lever and a ratchet gear shown in Figure 8 lock the bottom squeeze and a torsional spring will assist in opening the bottom squeeze to release. The release latch is conveniently located near the front of the chute where the rest of the actuating functions are operated. A set of cross-over cables, similar to the current head gate design, are used to actuate the bottom squeeze on the other side of the chute.

### **Squeeze Mechanism Dimensions and Further Analysis**

CAS consulted beef producers, OSU fact sheets, and ASAE standards to determine the operating dimension of the squeeze mechanism. Dimensions of cattle vary from breed to breed. This variation complicates the decision for the squeeze dimensions that will have the optimum effect on restraining the animal. Information from the three sources will determine the dimensions of the squeeze panels.

All of the beef producers consulted agreed that the current W-W design squeeze panel dimensions are fine for smaller animals or smaller built breeds such as Angus, etc. but the chute is not large enough for large cows or larger breeds such as Simmental or Chianina. The squeeze panels need to open wider at the bottom and the squeeze panels need to be longer. Table 1 from OSU Fact sheet F-1738 outlines suggested dimensions for different sizes of cattle.

#### **Animal Size**

---

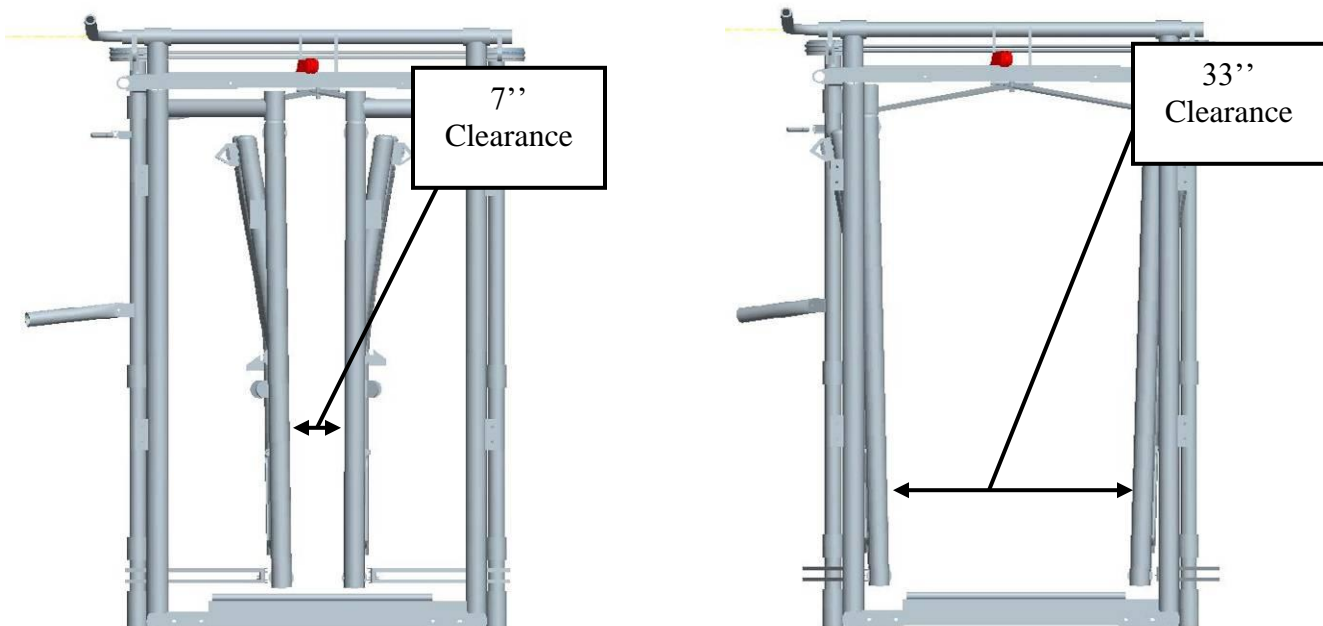




	to 600 lbs.	600-1200 lbs.	Over 1200 lbs. and cow calf operation
<b>Working Chute with Vertical Sides</b> Width	18"	20-24"	26-30"
<b>Working Chute with Sloping Sides</b> Width at bottom, inside clear	13"	15"	16"
Width at top, inside clear	20"	24"	28"

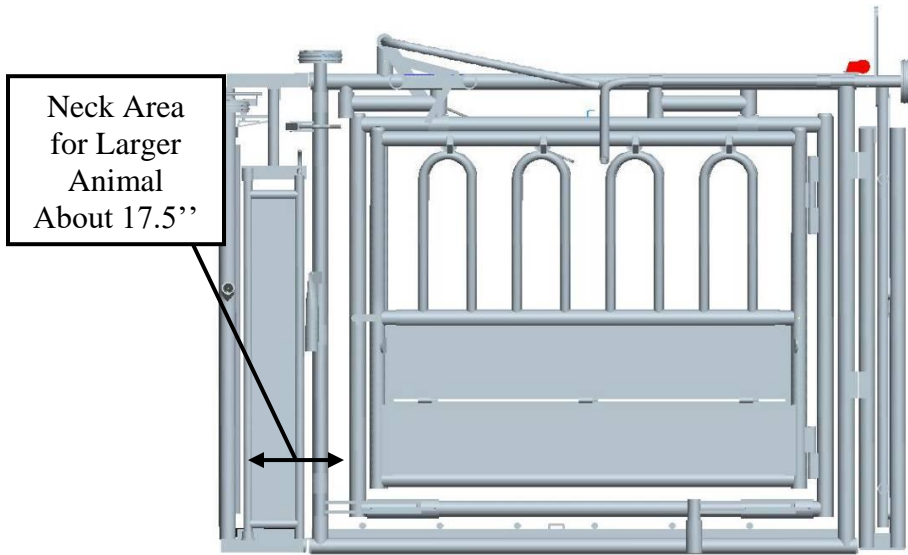
**Table 1. Suggested Chute Dimensions. Source: OSU Fact Sheet F-1738**

CAS analyzed ASAE Standard D321.2 JAN01 for chute dimensions as well. This standard gives dimensions of various animals. The thickest part of the animal occurs at the bulge of the belly. For a 1300 lb. steer this dimension is roughly 33 inches. The smallest thickness occurs at the center of the foreleg at the knee. This dimension is approximately 8 inches for a 200 lb. animal. Figure 9 displays the squeeze panels fully open and fully closed.

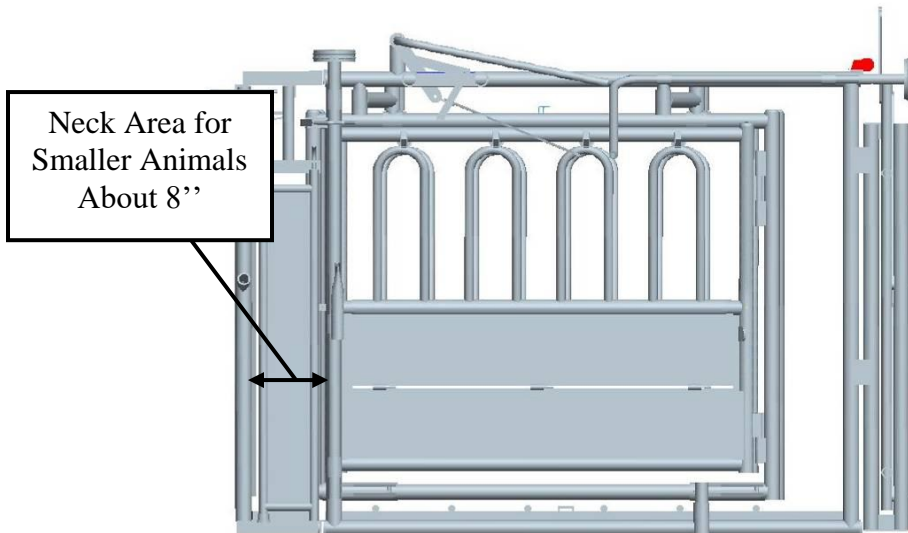


**Figure 9. Squeeze Panels Fully Open and Fully Closed**

The chute has the ability to squeeze down to a dimension of 7 inches and open to 33 inches when the squeeze panels are exactly parallel. The bottom squeeze can be varied in between these dimensions in order to give the squeeze panels a “V” effect or slope effect. The squeeze panels have the ability to move forward 9.5 inches when the squeeze panels are closed all the way. This gives 8 inches of neck area for a small calf. When the squeeze panels are open wide for a larger animal there is 17.5 inches of neck access.

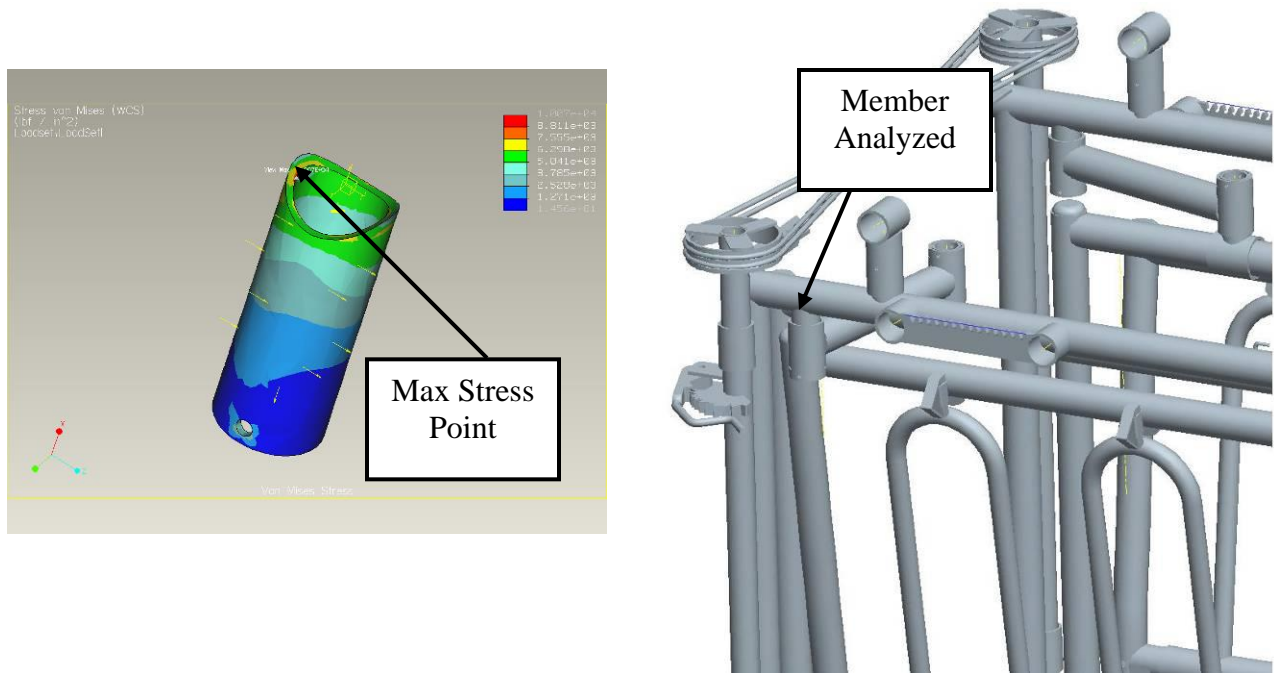


**Figure 10. Larger Animal Neck Access**



**Figure 11. Small Animal Neck Access**

CAS used Pro-Mechanica finite element software to determine the size of materials supporting the squeeze panels. The part expected to fail on the squeeze mechanism is the supports that the top linkages rotate about as shown in Figure 12.



**Figure 12. Finite Element Analysis**

The member in this analysis is 1.5” schedule 40 pipe. There are two 5/16” holes near the bottom of this member. The maximum stress on this member is approximately 10,000 psi. This gives a factor of safety of approximately 3. This member is more than strong enough for this application.

## Tailgate

In order to meet the desires of a larger range of W-W chute purchasers, CAS has employed multiple tailgate designs. Each tailgate design can be removed by simply removing eight bolts. This will allow each customer to have a choice between tailgates. When CAS approached W-W with this design, they indicated that the number of stocked parts may become a



problem with multiple options for tailgates. W-W suggested that the tailgate options should be limited to only two in order to keep stocked parts low. CAS developed two conceptual tailgates. The first is a guillotine/slider combination. The type of motion of the tailgate can be changed by simple rotating the tailgate and attaching or removing 4 extensions.

The guillotine/slider combination is a very powerful tool for a cattle operation facing many different tasks when working cattle. The guillotine portion of the gate is very convenient when working a large amount of cattle due to its easy actuation and ease of access. The slider portion of the tailgate is convenient when performing tasks such as artificial insemination.

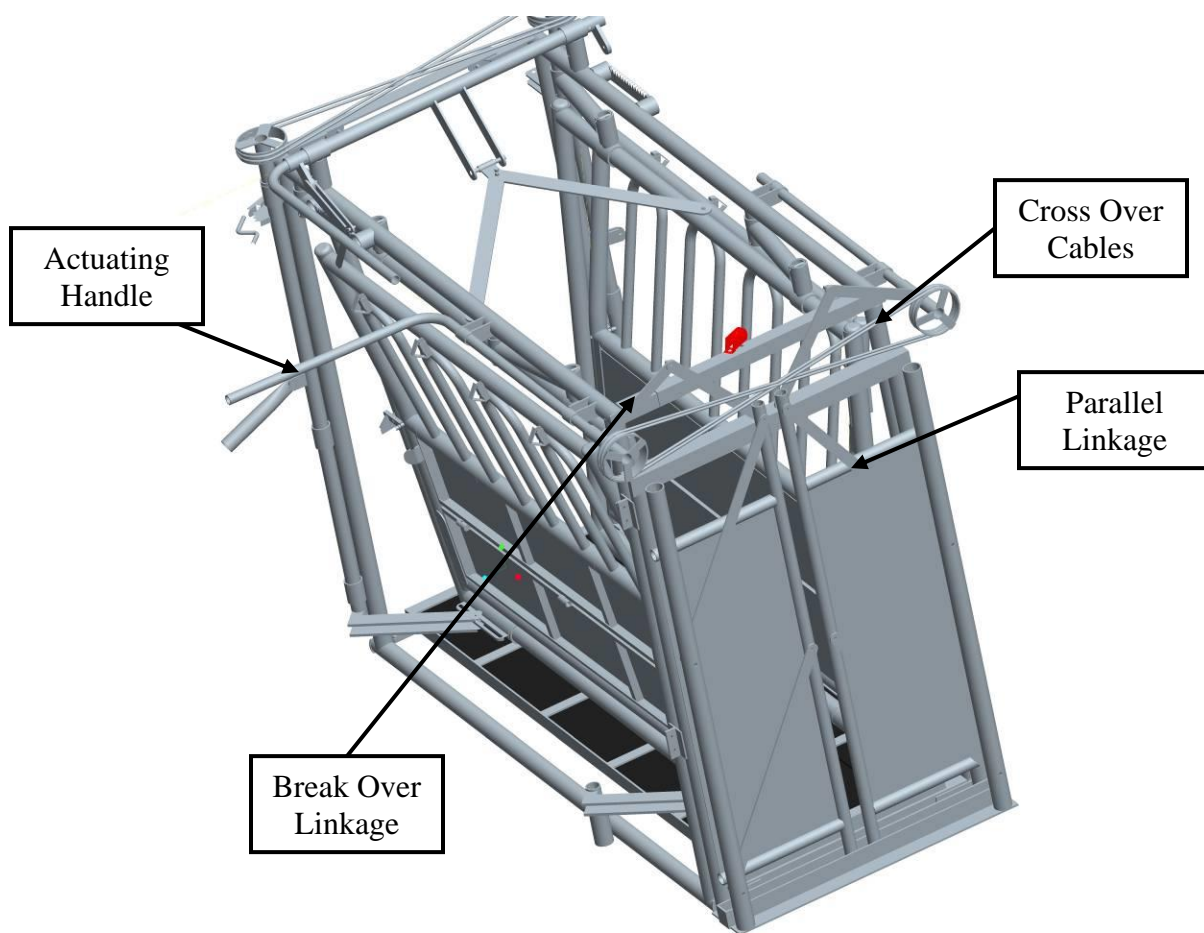
Figure 13 shows the concept guillotine/slider gate.



**Figure 13. Guillotine/Slider Tail Gate**



The scissor tailgate is the second option designed by CAS. Figure 14 demonstrates the major components involved in the conceptual design. The gate is actuated by pulling down on the actuation handle. The cross-over cables and parallel linkages make the scissor gate travel at a constant speed and position. Due to the placement of the linkages, the scissor gate will stay opened when fully open due to the linkages breaking over center. When the gate is closed, the lever is rotated past center and gravity will naturally close the gates quickly.



**Figure 14. Scissor Tail Gate**

## Floor

CAS has developed a new floor for the concept unit that incorporates rubber flooring. Rubber is a composite material that was developed as a shock absorbing medium in place of such materials as wood or steel. Rubber has a wide variety of uses such as injection molding, rotational molding, pressing into shapes, and extruding into sheets. Rubber flooring is desirable in corrosive locations. Rubber will not rust or deteriorate in the wet and corrosive locations that a chute may encounter. The rubber floor will also assist in lowering the noise levels while operating the chute.

In designing the support for the rubber flooring, CAS consulted the rubber web site [www.rumber.com](http://www.rumber.com). The web site gives suggestions for each application. In the section under livestock trailer flooring, the web site indicated that the spacing between the center supports should be between twelve and fifteen inches. The site also recommended 2 x 2 x ¼ inch angle iron as support members. Table 2 outlines the specifics of the rubber flooring.

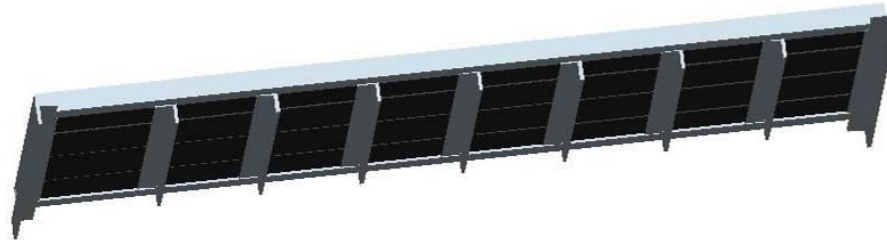
Test Method	Results		
Density/Specific Gravity	ATSM D 792	g/cc	0.982
Modulus of Elasticity	ATSM D 198	psi	28,000
Compression Strength	ATSM D 143	psi	19,000
Long Span Modulus	ATSM D 4761	psi	17,900
Perpendicular Compression Strength	ATSM D 143	psi	23,000
Ultimate Tensile Strength	ATSM D 143	psi	3,181
Water Absorption	ATSM D 1037	%	0.008
Screw Retention 3/8" lag bolt	ATSM E 588	lb	500
Abrasion Resistance	ATSM D 1037	in	0.02

**Table 2. Rubber Specifications. Source: [www.rumber.com](http://www.rumber.com)**

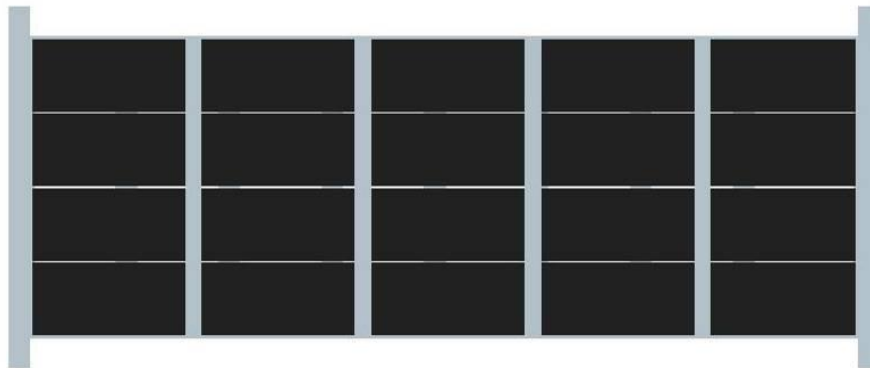
CAS employed a design with ten-inch center spacing with the recommended support steel. While securing the rubber to the base support, CAS used 1 x ½ x ¼ inch flat bar. The floor is placed before welding the straps across the top of the rubber for a fully secured floor. The ten



inch center spacing will insure that the rubber does not deflect past a point of plastic deformation. The conceptual floor can be seen in Figure 15 and 16.



**Figure 15. Bottom View of Conceptual Floor**



**Figure 16. Top View of Conceptual Floor**

## **Cost**

WW has stressed the importance of cost to CAS since the beginning of the project. In today's manual chute market, there are a number of competitors that build a cost effective chute. If the cost of a manual chute is too high, the customer will simply by another brand or they will purchase a hydraulic powered chute. Realizing that the manual chute market is such a niche market, CAS has avoided the use of unnecessary material and high manufacturing costs in the design.

After the conceptual design was completed, CAS created a bill of materials in Microsoft Excel. The entire chute is categorized by sub-assemblies. Each part in the sub-assembly is listed



below that sub-assembly. Each individual part is labeled with a description, material price, and labor price. With the cost information categorized in this manner, CAS and WW can analyze the cost very precisely. Table 3 summarizes the manufacturing, labor, and material cost for the fabricating the chute and all of the tailgate options.

<b>ITEM</b>	<b>TOTAL #</b>	<b>TOTAL COST</b>
Cuts	379	\$94.75
Saddles	32	\$8.00
Punches	138	\$34.50
Welds (in)	1530.5	\$505.76
<b>Total Labor Cost</b>		<b>\$643.01</b>
<b>Total Material Cost</b>		<b>\$536.28</b>
<b>Total Cost of WW Material</b>		<b>\$906.21</b>

**Table 3. Cost Breakdown**

Table 4 summarizes and compares the retail cost of the new chute design chute and the old chute design. CAS used a retail mark up of 120% for the retail cost analysis. The new chute design is more expensive than the old design. CAS feels that this extra cost is justified by the additional features and improved performance of the new chute design. Customers will witness the improved performance of the new chute design and decide that the chute is worth the additional cost. The Excel spreadsheet with the cost information is in Appendix D.

<b>ITEM</b>	<b>COST</b>	<b>COMBINATION</b>	<b>RETAIL VALUE (120% mark up)</b>
Basic Chute	\$1,599.53		
Guillotine tailgate	\$74.35	\$1,673.88	\$3,682.54
Combo tailgate	\$221.98	\$1,821.51	\$4,007.32
Scissor tailgate	\$189.64	\$1,789.17	\$3,936.16
Existing Chute	\$1,386.24		\$3,049.73

**Table 4. Retail Cost Comparison**



## Works Cited

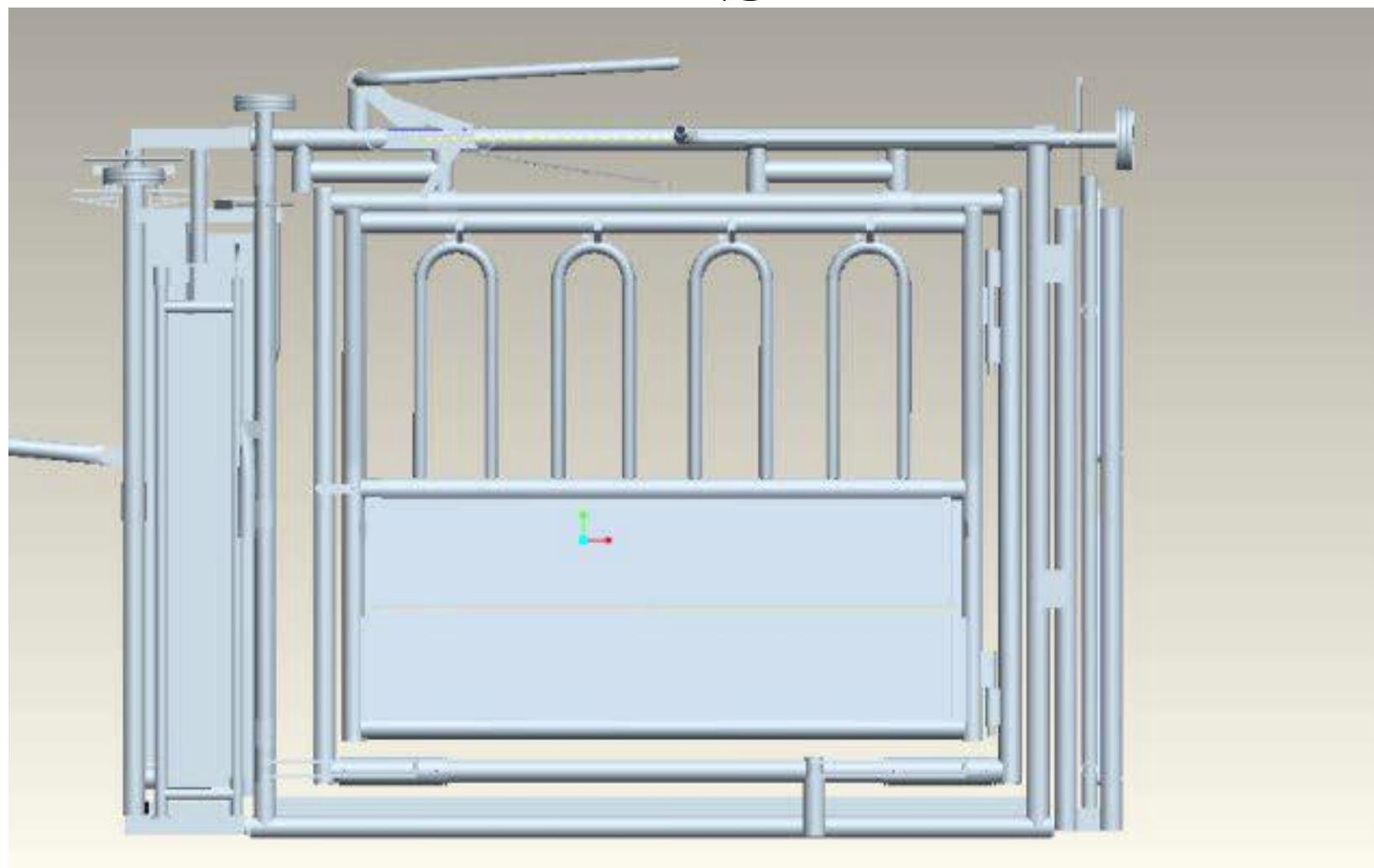
- ASAE Standards. 2001. D321.2: Dimensions of Livestock and Poultry.: ASAE
- Daniels, D. D. and D. Schmitz. 2003. Squeeze Chute Apparatus. U.S. Patent No. 6,609,480 B2.
- Grandin, T. Colorado State University. 2000. Restraint of Livestock: March 2000.  
Available at: <http://www.grandin.com/restrain/intro.rest.html>
- Hubert, D.J., R.L. Huhnke, S.L. Harp. Cattle Handling Safety in Working Facilities. Oklahoma State University Cooperative Extension Service.
- Maghirang, R. G., B. A. Peterson, C. W. Schoonover, M. D. Schrock, and S. D. Vermillion. 2001. Development of an Energy-Absorbing Headgate for Cattle Squeeze Chutes. *Applied Eng. In Agric.* 17 (2): 577-581.
- Pearson, L. B. 1977. Livestock Squeeze Chute. U.S. Patent No. 4,027,629.
- Rumber. 2000. Rumber Specifications Sheet: Available at <http://www.rumber.com/specs.htm>.  
Accessed December 5, 2005







# “BEEFMASTER II”



Joe Biggerstaff

William Ryan Haar

Matt Kilker

Taylor Miller





# CAS Design Group Assignment

Custom Agricultural Solutions (CAS) has been assigned with the task of improving the design of a manually operated cattle chute.





# Overview

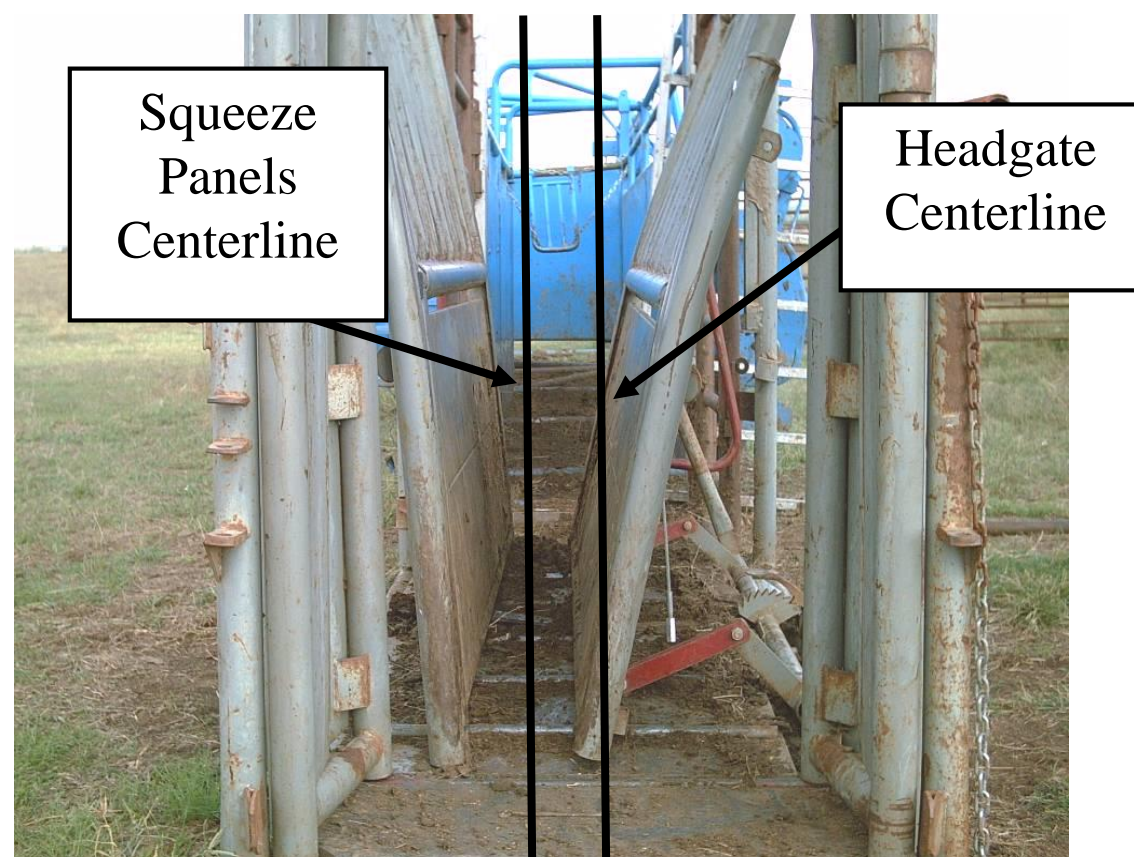
- Current Issues
- Testing and Operation
- Patent and Literature Research
- Design Criteria
- Concept Design
- Cost Analysis
- Future Plans





# Squeeze Mechanism Issues

- One Sided Squeeze
- Misalignment of Cattle
- One Sided Control
- Emergency Exit
- Reliability
- Noise Reduction







# Head Gate Issues

- Unreliable Latch
- Unable to Open Front Latch by Itself
- One Sided Control







# Tailgate Issues

- Operator Lifting Force
- Hanging Rope
- Noise Reduction





## Miscellaneous Issues

- Rumber Floor
- Metal on Metal Contact
- Yoke Trailer
- Dimensions of Chute







# Testing and Observations

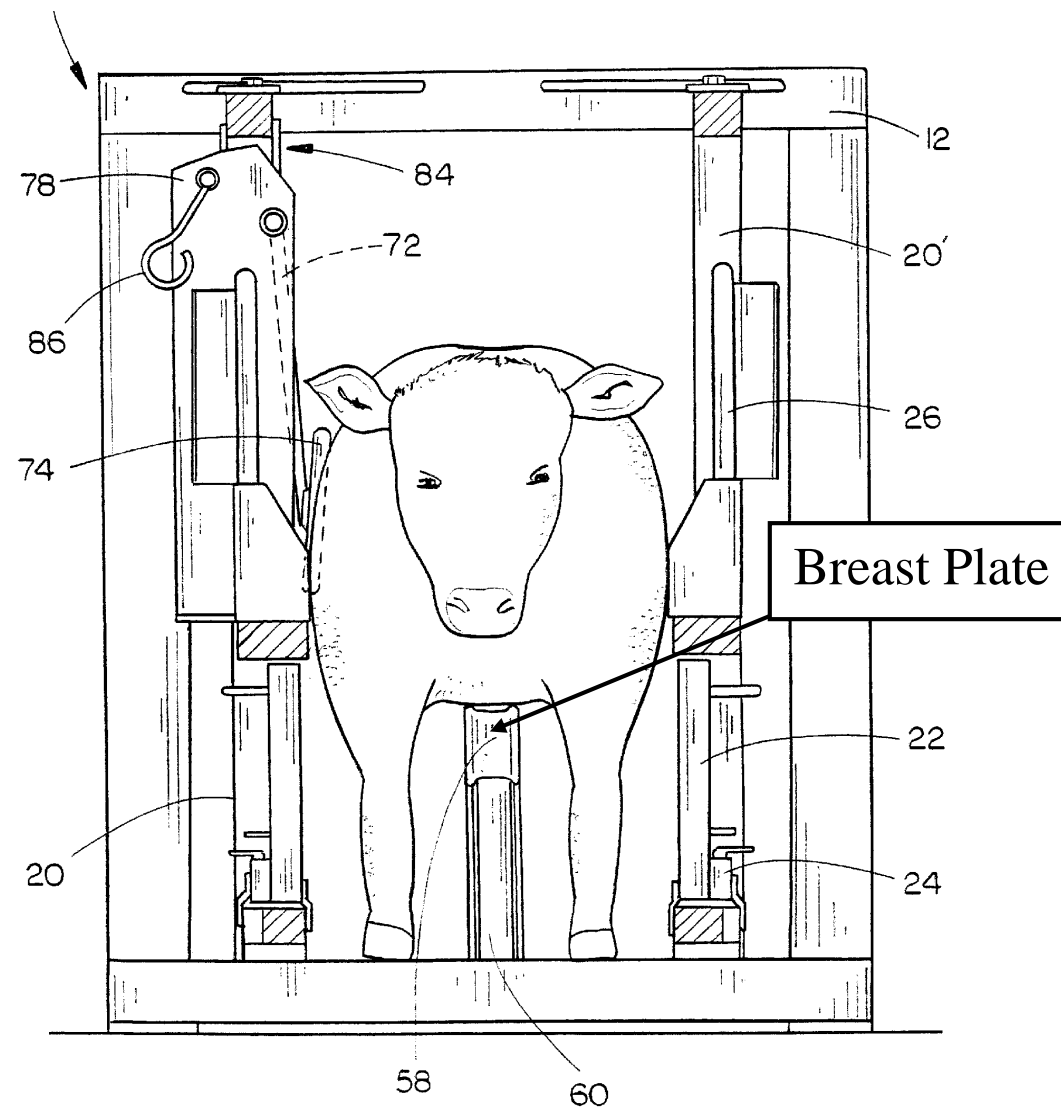
- Interviewed Ranchers Across Oklahoma
- Learned Customers Needs
- Operated Six Year Old Chute
- Analyzed Chute Size





# Patents

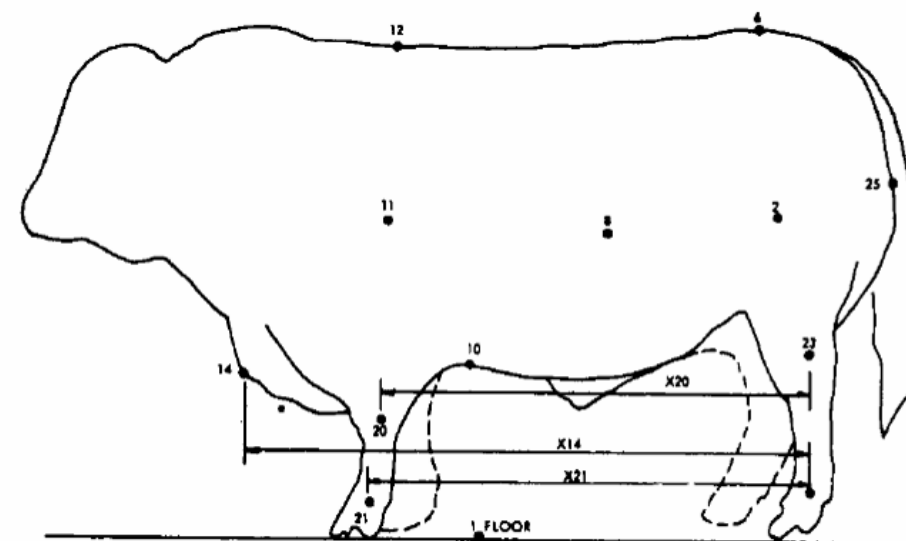
- Squeeze
- Head Catch
- Tailgate
- Breast Plate





# Literature Review

- Head Gate Forces
- Bovine Size
- Noise
- Solid Barriers (Restrict Vision)
- Optimal Pressure
- Non-slip Floor

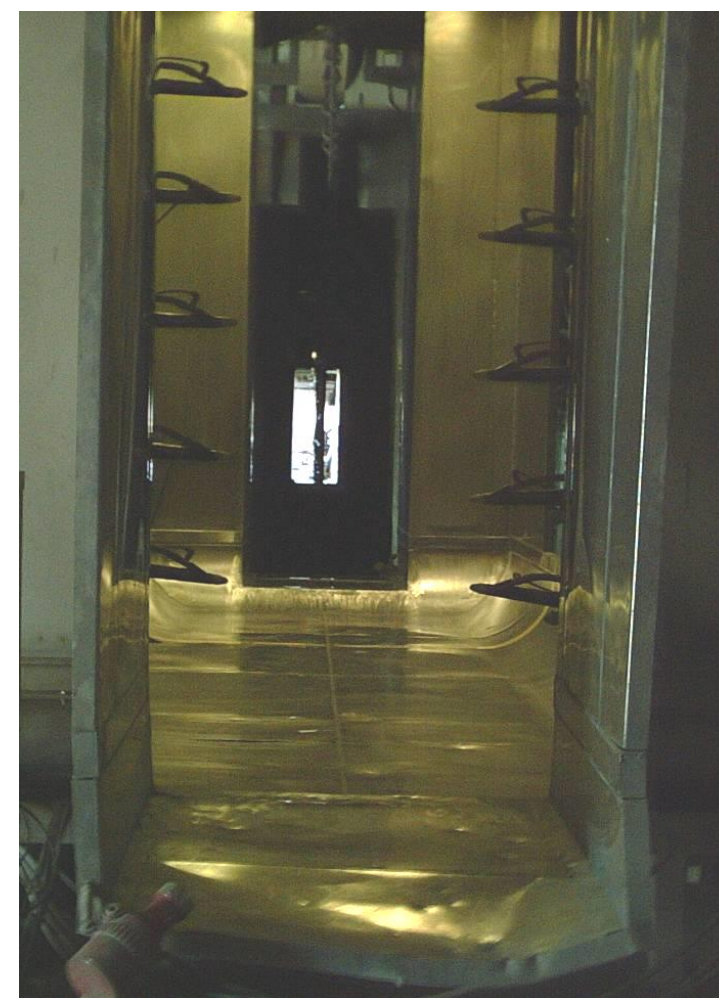






# Design Criteria

- Fit In Powder Coater
- Maintain Saddled Pipe Practice
- Squeeze From Both Sides
- Maintain Emergency Exit
- Reduce Noise

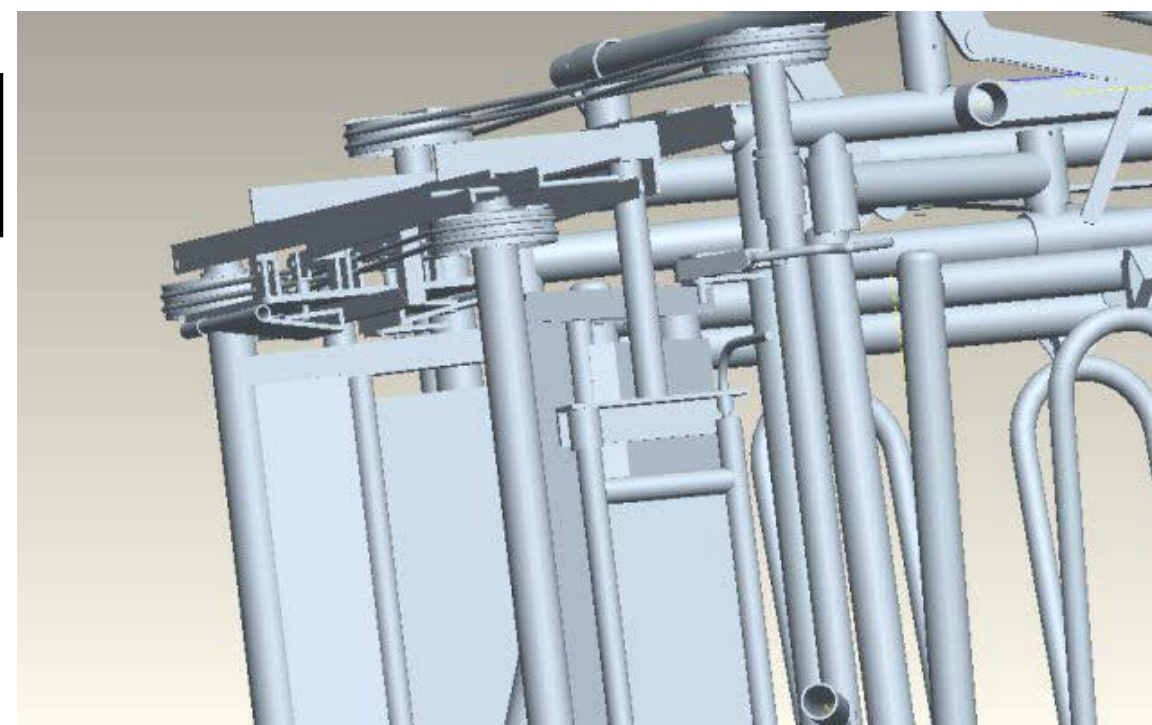
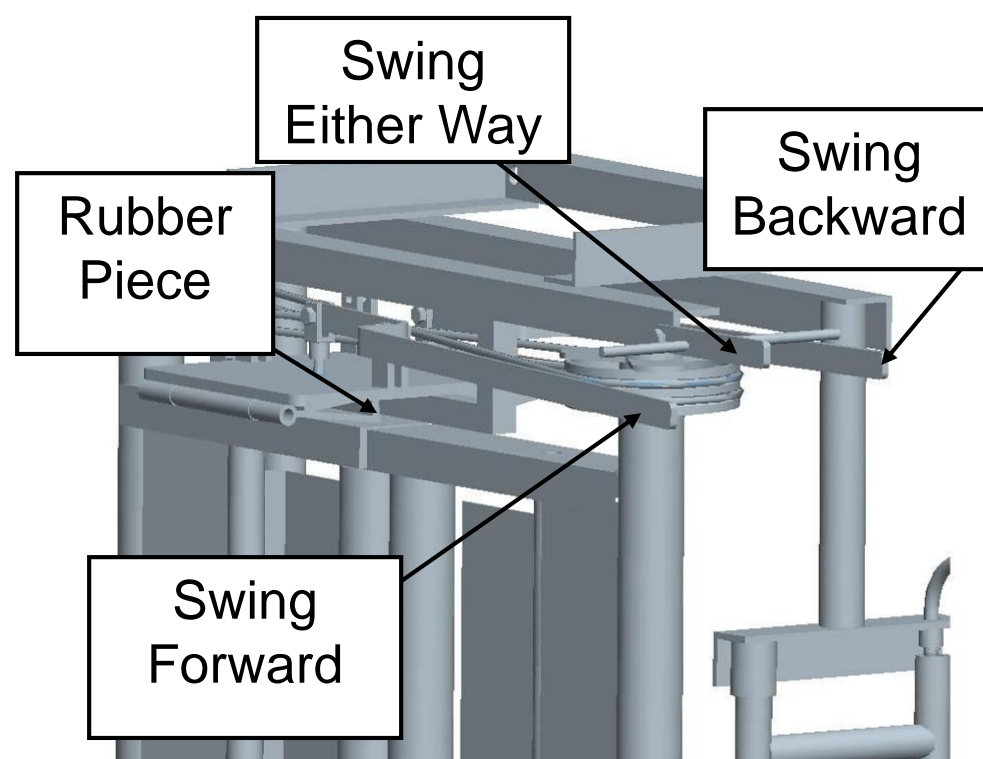




# Head Gate Design

## Three Lever Double Latch

- Front, Back, and Combo Release
- Rubber Faced Stop Surface

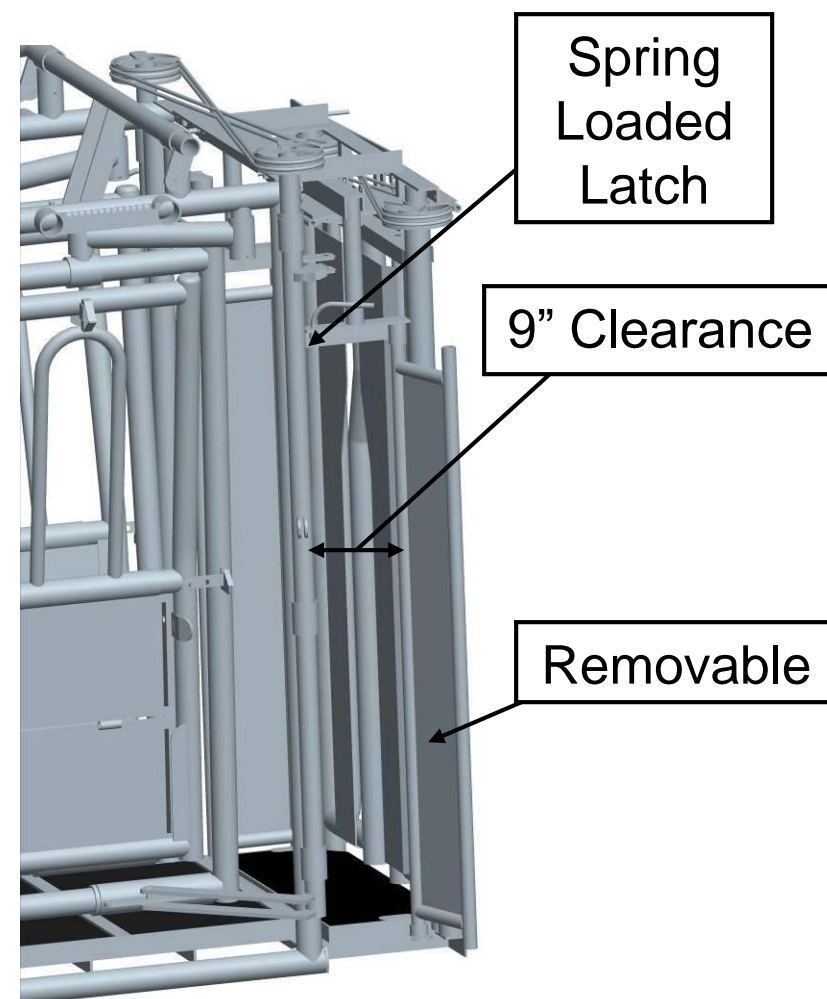




# Head Gate Design

## Neck Access Panel

- Increased neck access
- Solid Wall  
(Vision Impairment)
- Both Sides



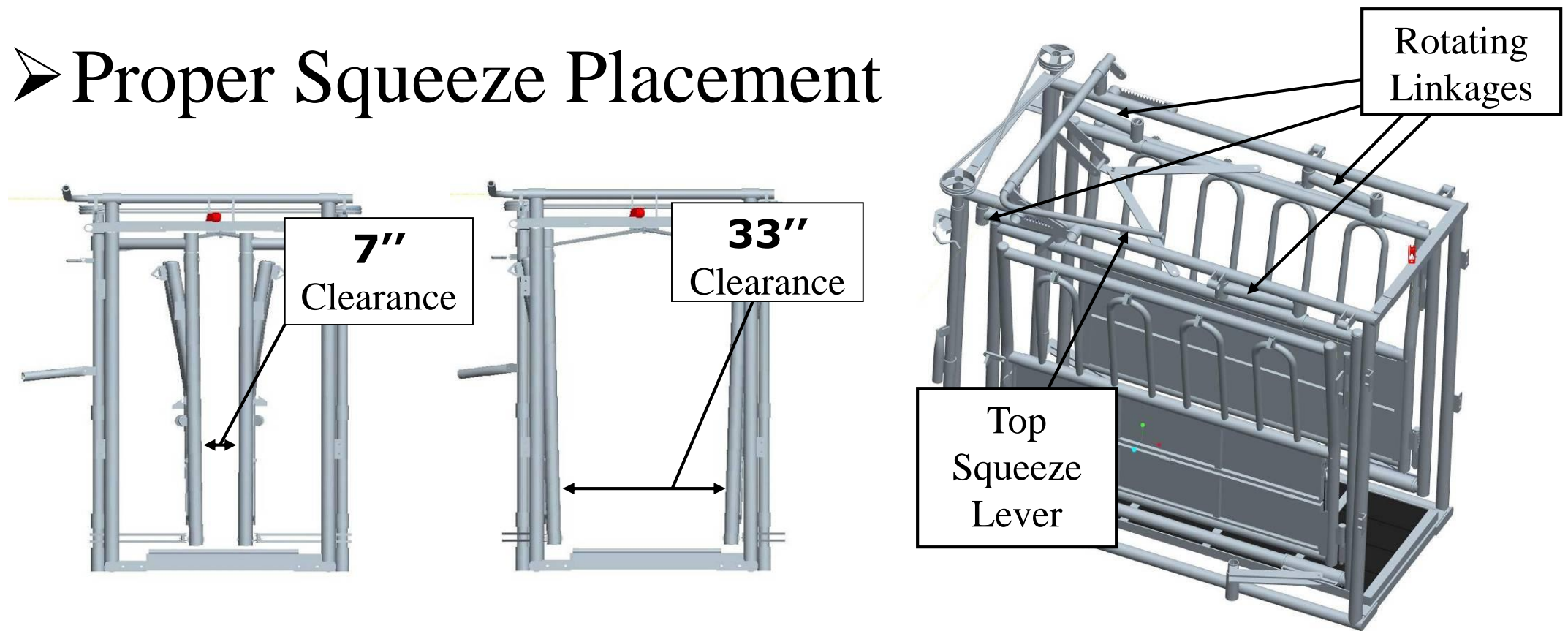




# Squeeze Mechanism Design

## Movement

- Safer Lever Position
- Inward and Forward Movement
- Proper Squeeze Placement

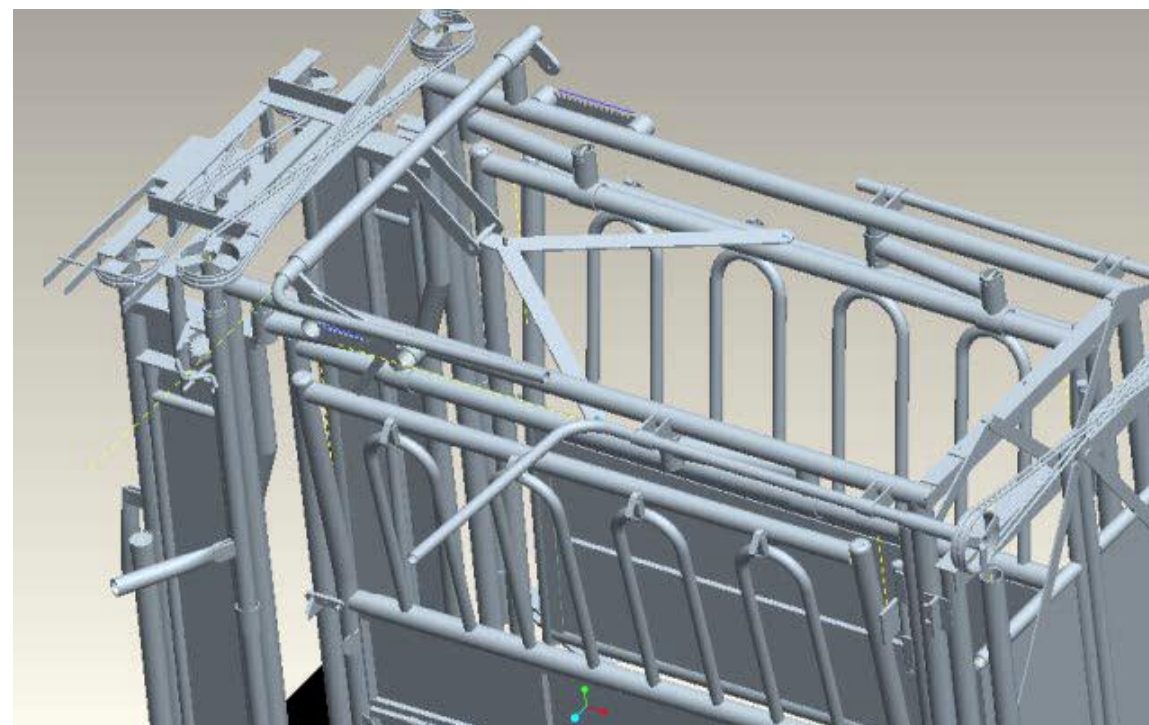
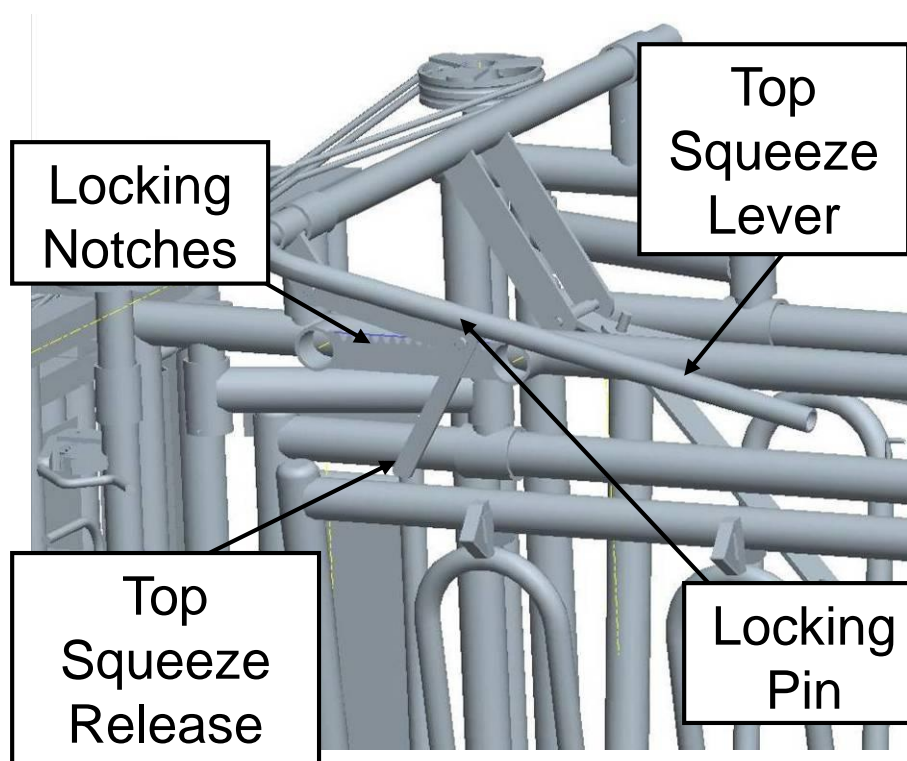




# Squeeze Mechanism Design

## Top Squeeze

- Self-Locking
- Easy Release
- Scissor Linkage



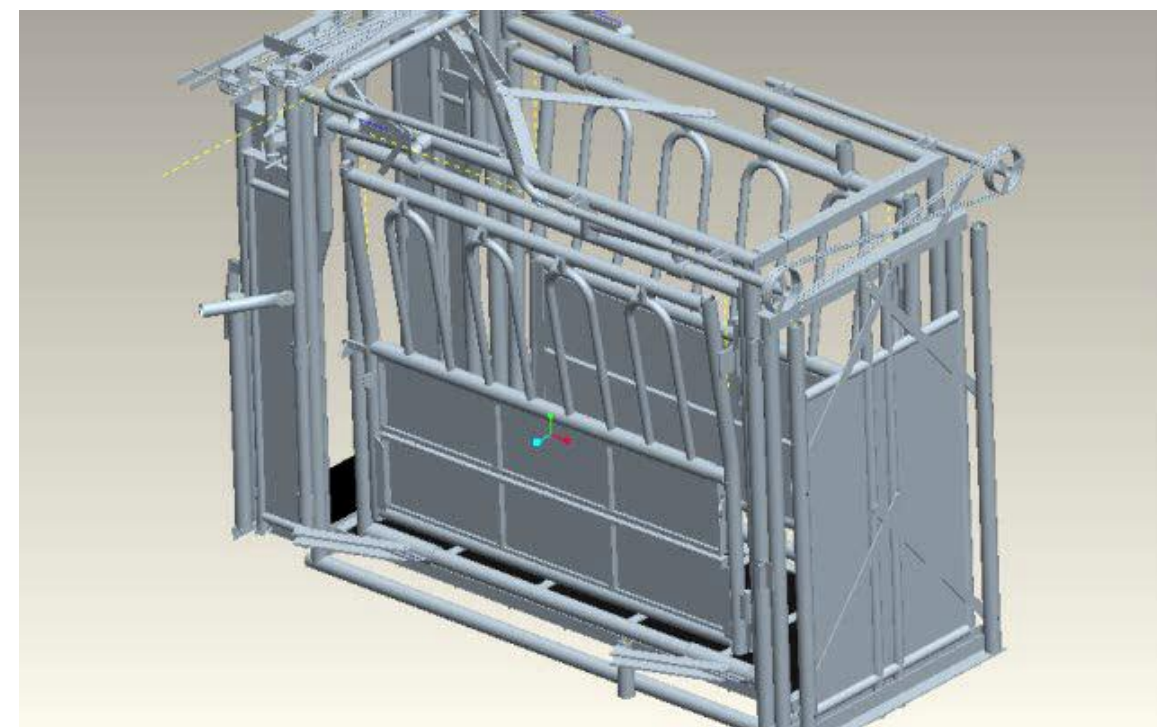
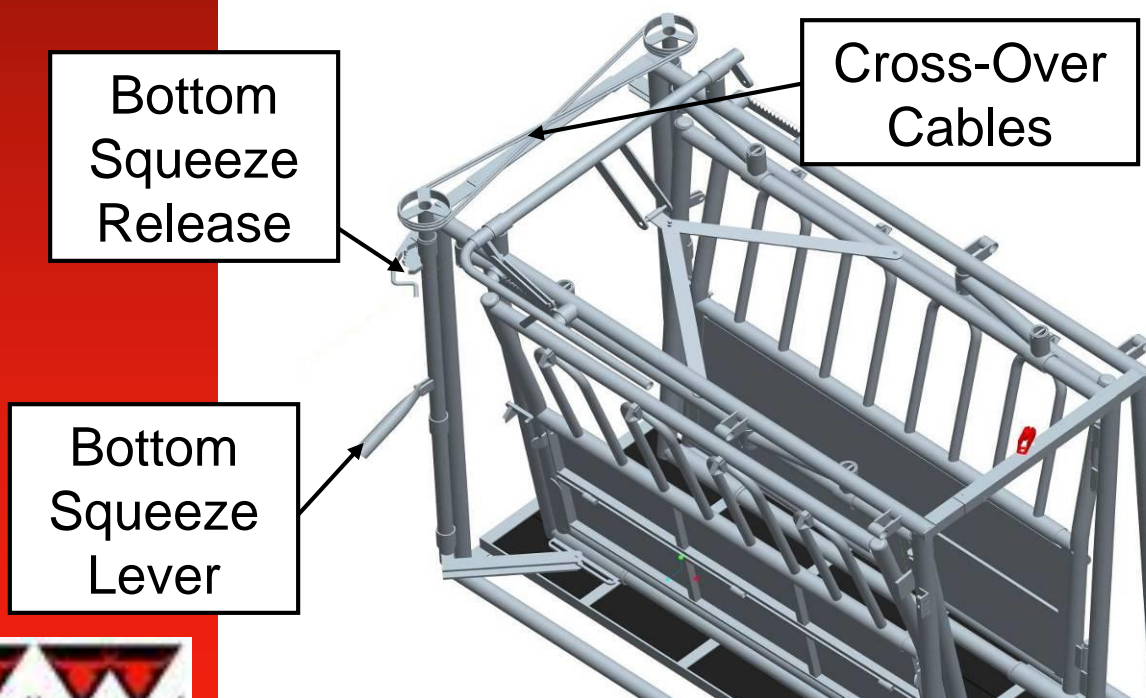




# Squeeze Mechanism Design

## Bottom Squeeze

- Proven Parts
- Fold Down Lever
- Self Latching

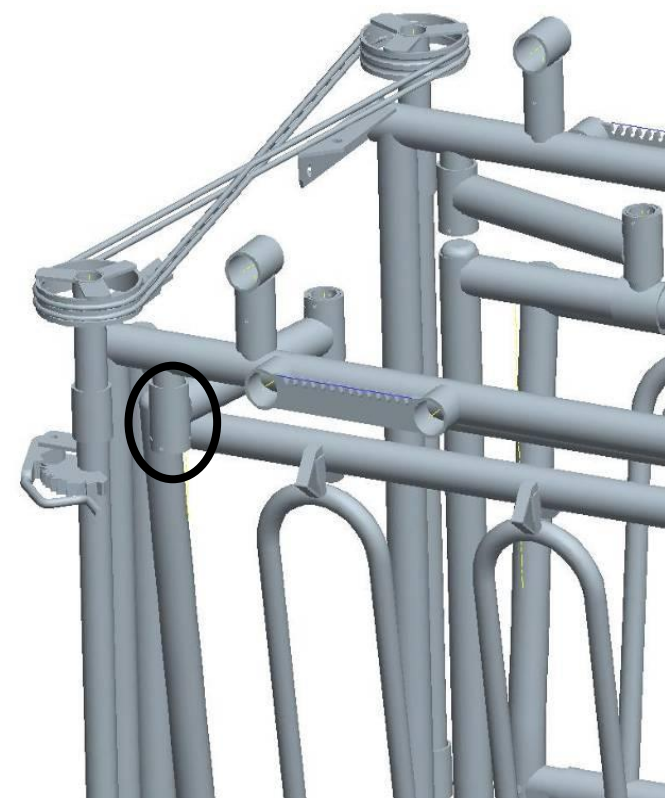
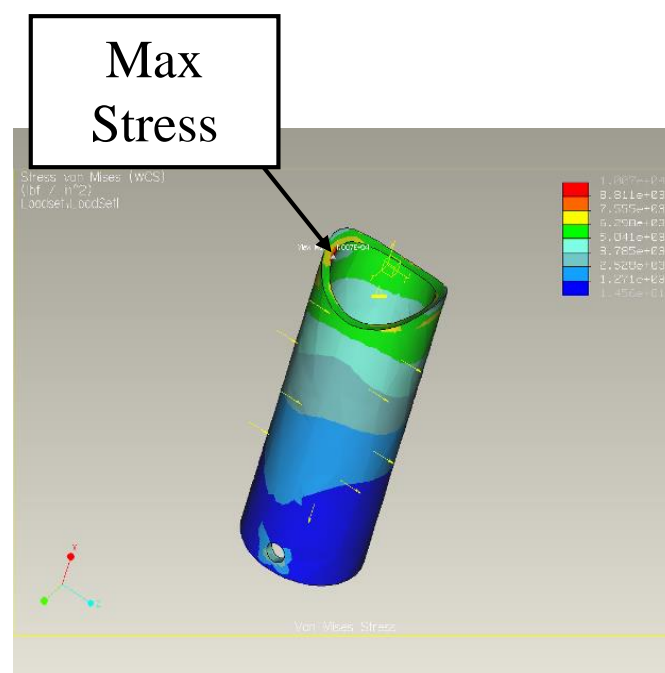




# Squeeze Mechanism Design

## FEA Analysis of Critical Parts

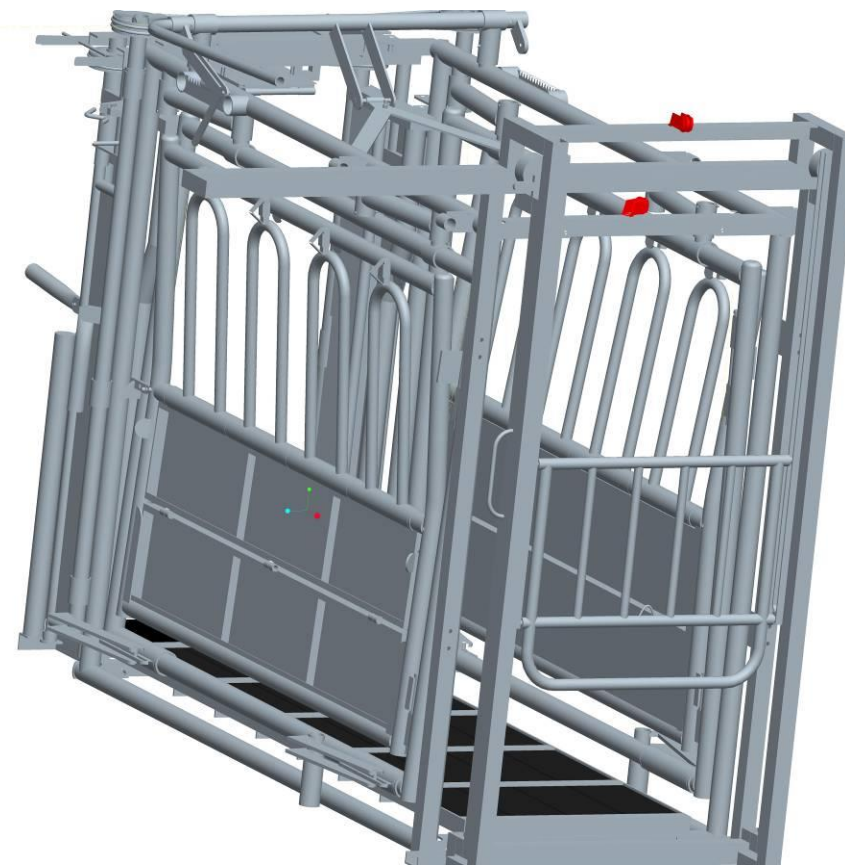
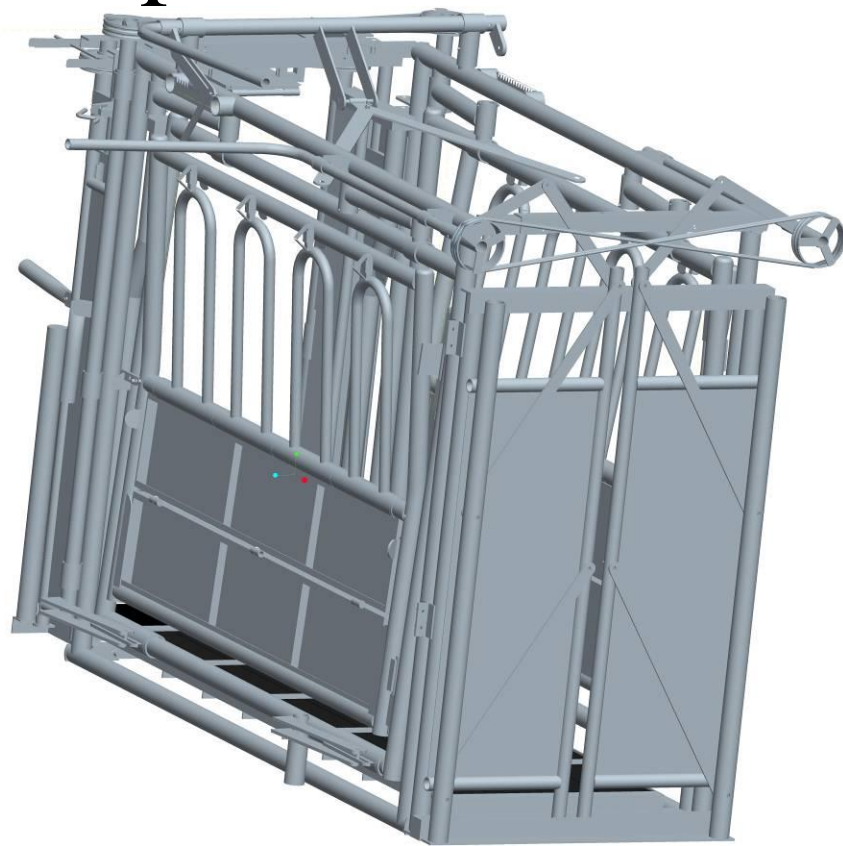
- Stress
- Deflection





# Tailgate Design

- Ease of Operation
- Multiple Tailgate Designs
- Simple Attachment



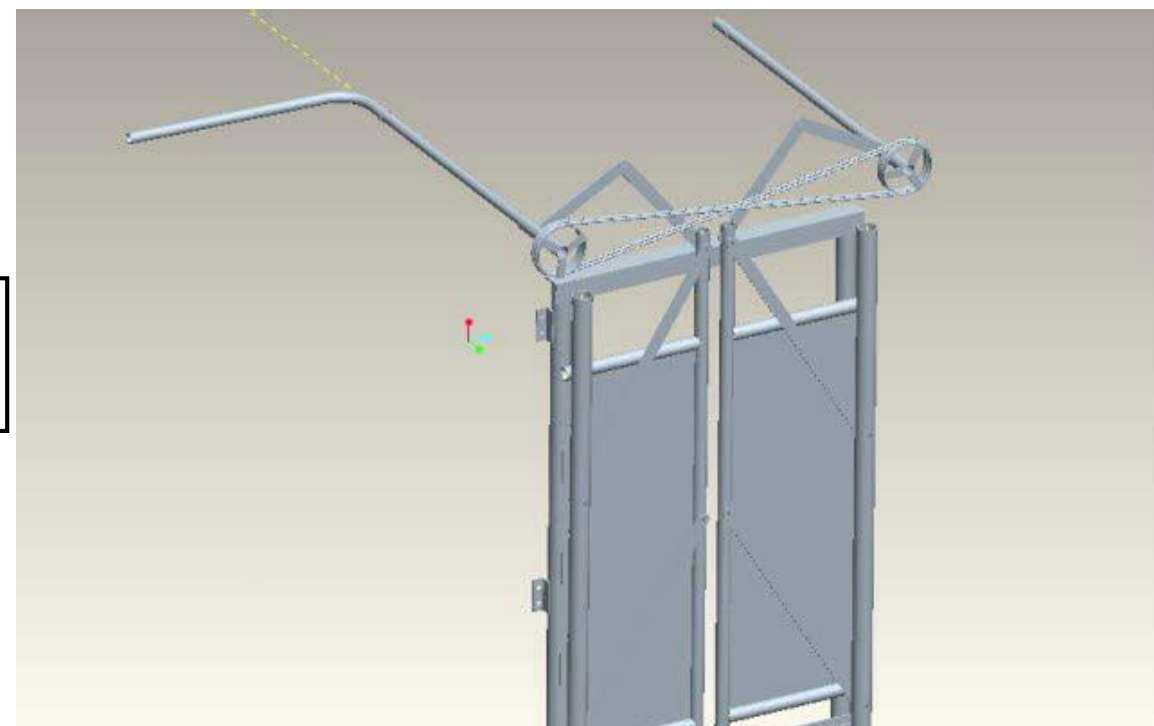
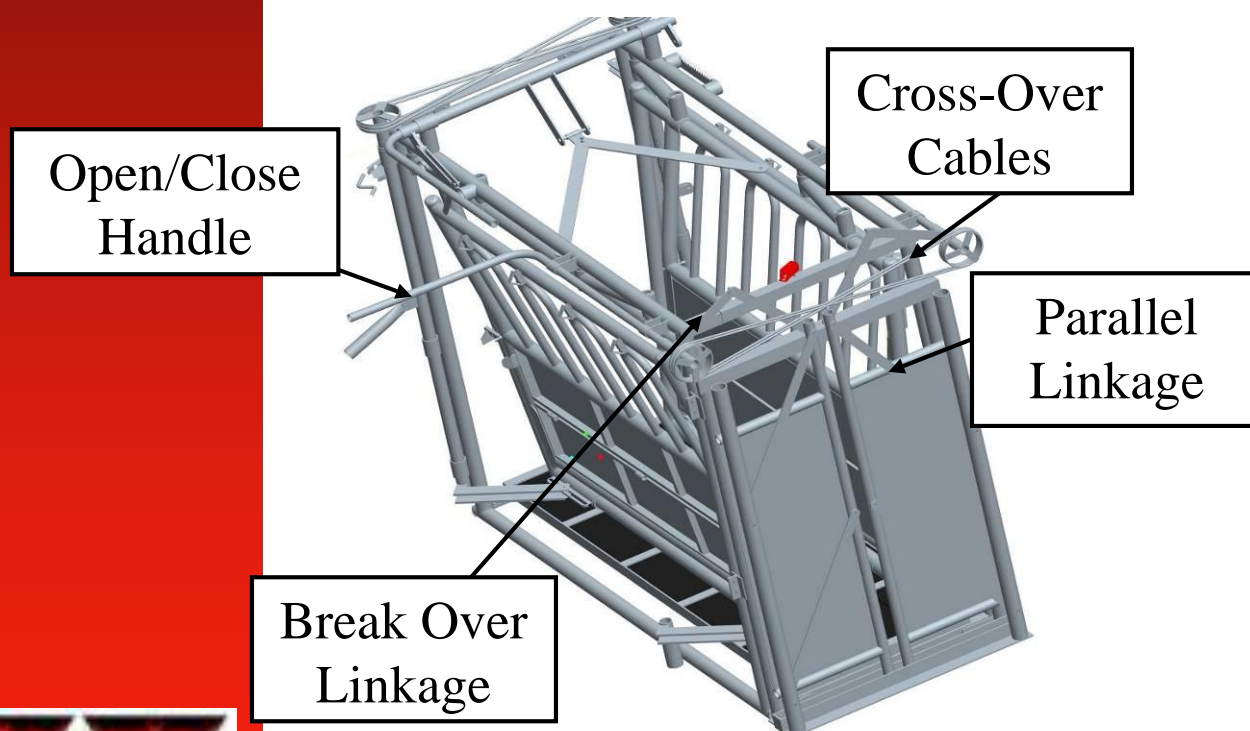




# Tailgate Design

## Scissor Gate

- Gravity Powered
- Self-Locking
- Proven Parts

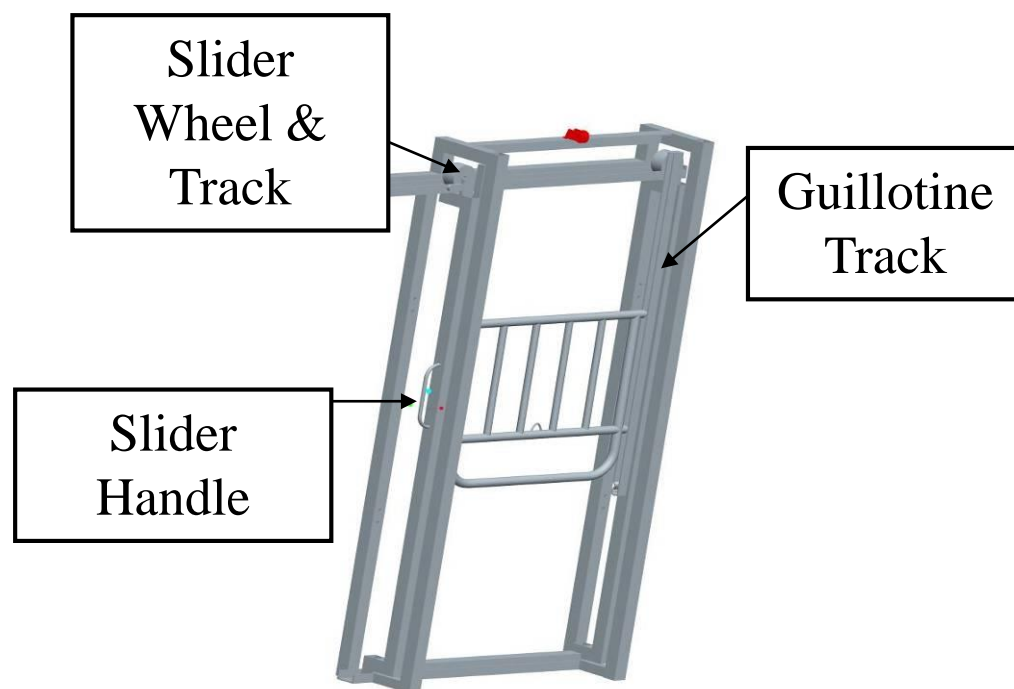






# Tailgate Design Guillotine/Slider

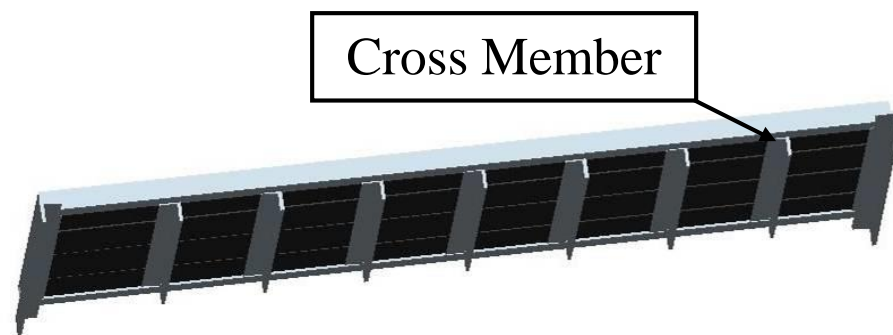
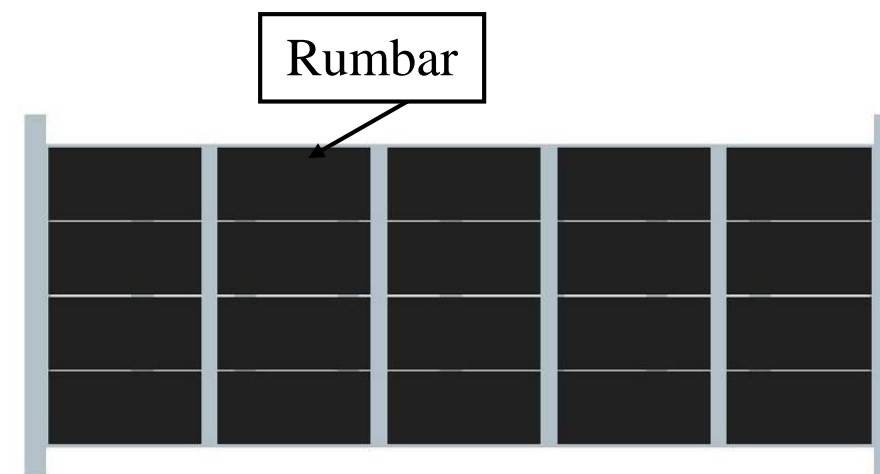
- Quickly Change Modes
- Multiple Applications
- User Friendly





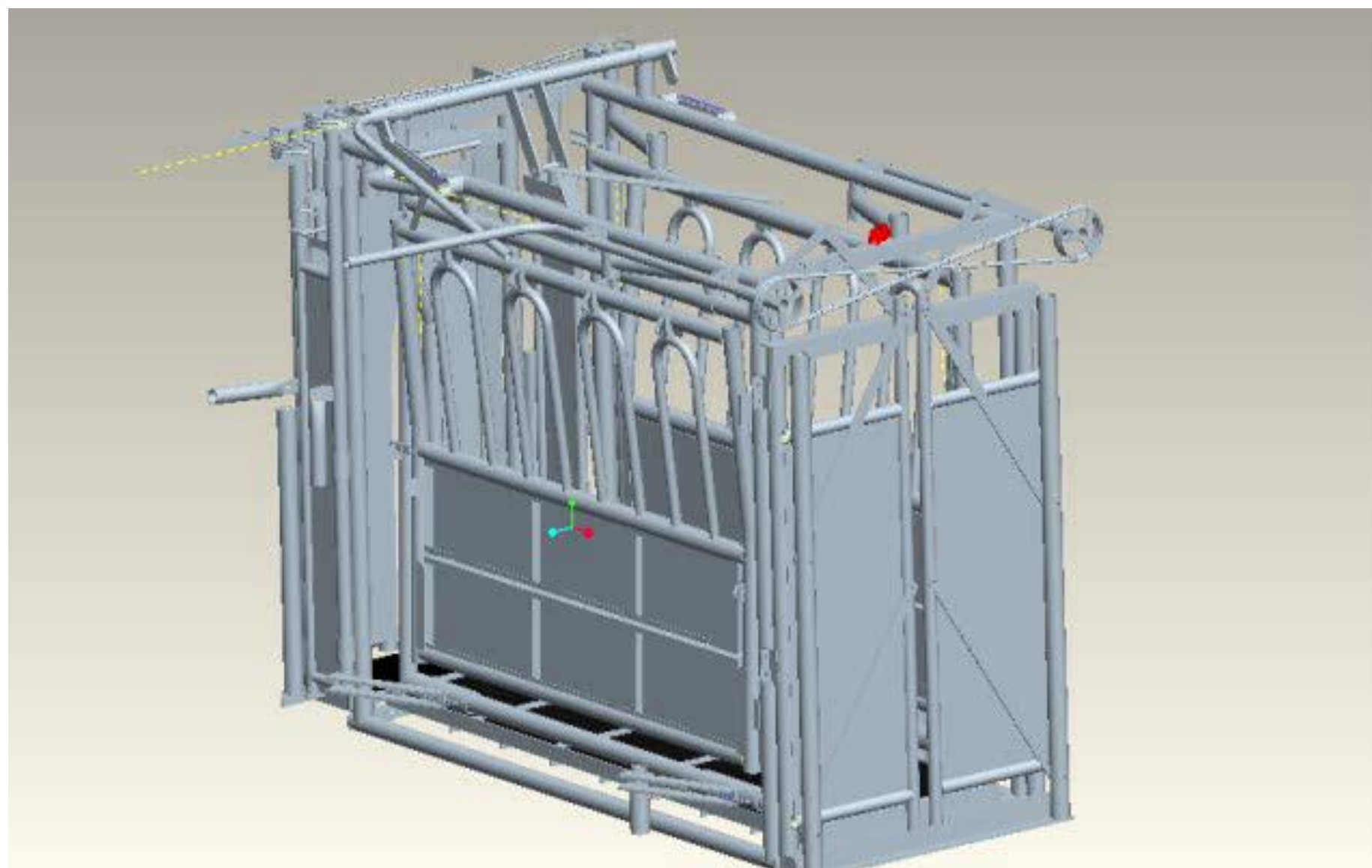
# Floor Design

- Noise Reduction
- No Slip Floor
- Easy Manufacturing





# Proposed Design





# **CUSTOM AGRICULTURAL SOLUTIONS**



## Cost Analysis

ITEM	COST	COMBINATION	RETAIL VALUE (120% mark up)
Basic Chute	\$1,600		
Guillotine tailgate	\$74	\$1,674	\$3,683
Combo tailgate	\$222	\$1,822	\$4,007
Scissor tailgate	\$190	\$1,789	\$3,936
Existing Chute	\$1,386		\$3,050

ITEM	TOTAL #	TOTAL COST
Cuts	379	\$95
Saddles	32	\$8
Punches	138	\$35
Welds	1531	\$506
Total Labor Cost		\$643
Total Material Cost		\$536
Total Cost of WW Material		\$906
Total Cost of Prodotype		\$2,086



**PERFORMANCE ENGINEERED**

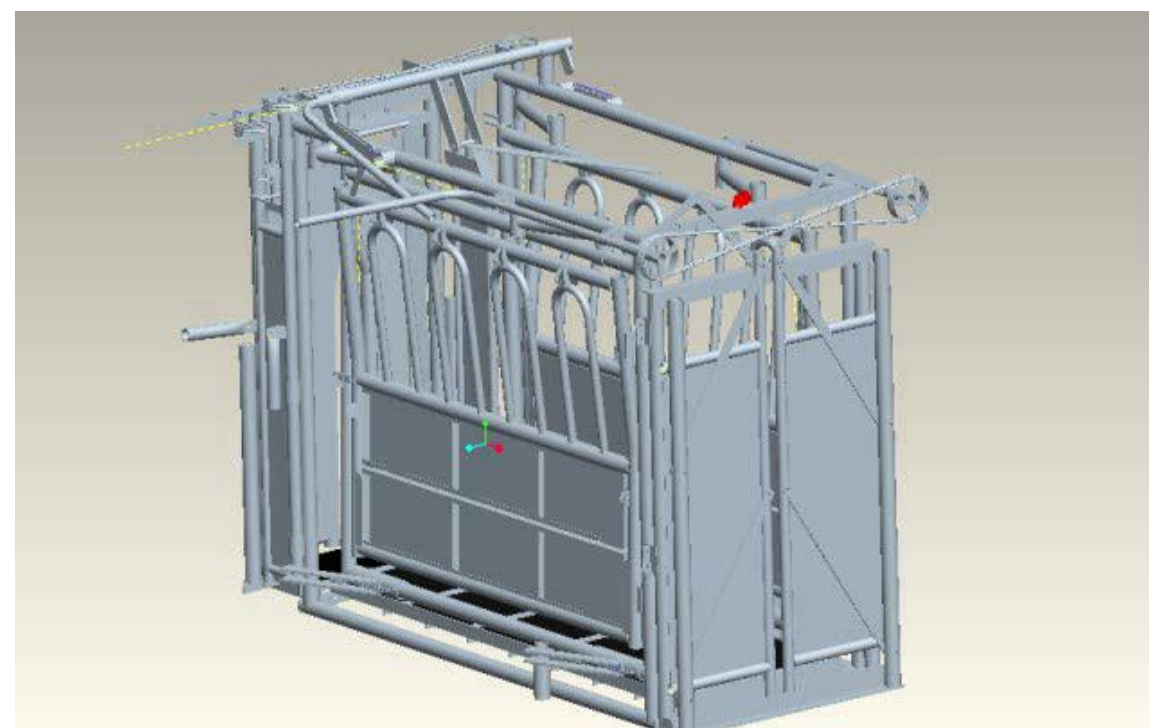






## Future Plans

- Complete Manufacturing Documentation
- Produce Concept
- Test Concept
- Modifications
- Present Final Design





# Thank You

- Greg Overton, General Manager
- Pat Carhart, Sales Manager
- Don Lake, Applications Engineer
- Dr. Paul Weckler, Assistant Professor
- Dr. Glenn Brown, Professor
- Rolling R3 Ranch





**CUSTOM AGRICULTURAL SOLUTIONS**



Questions?

